



Architecture

21026

Venice

Italy

Venise

Italie

Venezia

(Italia)



LEGO.com/architecture

Venice

Built on over 100 islands in a marshy lagoon at the edge of the Adriatic Sea, Venice has a skyline that rises from the water to create a unique architectural experience. There are no roadways or cars in the historic city; instead 177 canals crossed by over 400 bridges give access to innumerable narrow, mazelike alleys and squares.

While the origin of the city dates back over 1500 years, the golden age of Venice occurred during the late Middle Ages and Renaissance periods when it became one of the most powerful republics in the eastern Mediterranean.

Today the city is facing major challenges including gradual subsidence, flooding, and problems caused by its popularity as a tourist destination. More than 60,000 people visit Venice each day—more than the population of the city itself—putting pressure on the city to accommodate these guests while maintaining its unique nature and identity.



Rialto Bridge

The Rialto Bridge (Ponte di Rialto) spans the Grand Canal at the heart of the historic city. Built between 1588 and 1591, it replaced earlier wooden bridges that had linked the districts of San Marco and San Polo since the 12th century.

When the last wooden bridge collapsed in 1524, several projects were considered before the city authorities requested plans for a stone bridge in 1551. The architect Antonio da Ponte competed with illustrious competitors such as Michelangelo and Palladio before winning the contract.

His single span design with a 24 ft. (7.5 m) arch included three walkways: two along the outer edges and a wider central walkway between two rows of small shops. The entire structure was built on some 12,000 wooden pilings that still support the bridge over 400 years later.

[“To build a city where it is impossible to build a city is madness in itself, but to build there one of the most elegant and grandest of cities is the madness of genius.”]

Alexander Herzen



Rialto Bridge

Bridge of Sighs

Bridge of Sighs (Ponte dei Sospiri) is an enclosed bridge constructed in white limestone that passes over the Rio di Palazzo, connecting the old city prison to the interrogation rooms in the Doge's Palace. Designed by Antonio Contino, the nephew of Antonio da Ponte who created the Rialto Bridge, the bridge was completed in 1602.

The bridge's romantic name is thought to refer to the sighs of convicts as they saw their last view of Venice before being taken to their prison cells. In reality, very little of the city could be seen through the stone grills covering the windows and the majority of prisoners at that time were small-time criminals.

["I stood in Venice, on the
Bridge of Sighs, A palace
and a prison on each hand."]



St. Mark's Campanile

As one of the tallest structures in the city, St. Mark's Campanile (Campanile di San Marco) is one of Venice's most recognizable symbols. From here the visitor has an incredible view of the city and lagoon as well as the Italian Alps in the distance.

The 323 ft. (98.6 m) bell tower stands alone in the corner of St. Mark's Square, near the front entrance to the basilica. The brick structure is 39 ft. (12 m) wide on each side and 160 ft. (50 m) tall, upon which sits a belfry housing five bells. A spire caps the tower with a golden weather vane on top.

Though the design of the Campanile is from the 16th century, the tower itself was completely rebuilt in 1912 after the original one collapsed in 1902. The inauguration of the new tower occurred exactly 1000 years after the foundation of the original tower was laid.



St. Mark's Campanile

St. Mark's Basilica

St. Mark's Basilica (Basilica di San Marco) is the most famous church in Venice and the best-known example of the city's unique Italo-Byzantine architecture.

Built to house the relics of Mark the Evangelist, little is known about the original church buildings, but the current structure is thought to have been constructed between 1073 and 1093. The basilica is laid out in the design of a Greek cross and the tallest of the five domes reach 141 ft. (43 m) in height.

While the layout of the church has remained constant over the centuries, the decoration on the inside and outside of the church has changed greatly. Venice's involvement in crusades and conquests saw mosaics, columns, and friezes from all over the Mediterranean

added to the original opulent, golden mosaic interior. Outside, the exterior brickwork was gradually covered with marble cladding and carvings as Venetian vessels returned with the spoils of war and trade.

A symbol of the wealth and power of the Venetian Republic, St. Mark's Basilica remains one of the city's most impressive landmarks today.



St. Mark's Basilica

St. Theodore and the Lion of Venice columns

Two granite columns stand guard at the entrance to St. Mark's Square (Piazza di San Marco).

On top of the western column is a statue of St. Theodore, the first patron of the city. Here he holds a spear and his foot rests upon a crocodile—representing the dragon he was said to have slain. On the eastern column stands the winged Lion of Venice, the symbol of the second patron of the city, St. Mark.

Both columns are believed to have been erected in about 1268 and it is believed that the city executed convicted criminals between the two columns in days gone by. To this day, superstitious Venetians avoid walking between this pair of columns.

[“There is a glorious city in the sea. The sea is in the broad, the narrow streets, Ebbing and flowing... ”]

Samuel Rogers



St. Theodore and the Lion of Venice columns

Venise

Construite sur plus de 100 îles dans une lagune marécageuse au bord de la mer Adriatique, Venise s'élève de l'eau pour créer une expérience architecturale unique. Cette ville historique ne contient ni routes ni voitures, mais plutôt 177 canaux traversés par 400 ponts qui donnent accès à d'innombrables allées étroites et labyrinthiques, ainsi qu'à des places publiques.

Si l'origine de la ville remonte à plus de 1 500 ans, l'âge d'or de Venise eut lieu à la fin du Moyen Âge et à la Renaissance, lorsqu'elle devint l'une des plus puissantes républiques de la Méditerranée orientale.

La ville affronte aujourd'hui de nombreux défis y compris un affaissement graduel, des inondations et des problèmes causés par sa popularité comme destination touristique. Plus de 60 000 personnes visitent Venise chaque jour, ce qui est supérieur à la population de la ville, exerçant une pression sur la ville pour accueillir ces visiteurs tout en préservant sa nature et son identité uniques.



Le pont du Rialto

Le pont du Rialto (Ponte di Rialto) traverse le Grand Canal au cœur de la ville historique. Construit entre 1588 et 1591, il a remplacé les ponts antérieurs en bois qui reliaient les quartiers de San Marco et de San Polo depuis le XII^e siècle.

Lorsque le dernier pont en bois s'écroula en 1524, plusieurs projets furent envisagés avant que les autorités de la ville ne demandent des plans pour un pont en pierre en 1551. L'architecte Antonio da Ponte rivalisa avec des concurrents illustres tels que Michel-Ange et Palladio avant de gagner le contrat.

Son design à travée unique avec une arche de 7,5m incluait trois allées : deux de chaque côté et une allée centrale plus large entre deux rangées de petits magasins. Toute la structure fut construite sur plus de 12 000 piliers qui supportent toujours le pont plus de 400 ans plus tard.

[« Construire une ville là où il est impossible de construire une ville est de la folie, mais d'y construire l'une des villes les plus élégantes et les plus grandioses est la folie d'un génie. »]

Alexandre Herzen



Le pont du Rialto

Le pont des Soupirs

Le pont des Soupirs (Ponte dei Sospiri) est un pont fermé construit en pierre calcaire blanche qui passe sur le Rio di Palazzo, reliant la vieille prison de la ville aux salles d'interrogatoire du Palais des Doges. Conçu par Antonio Contino, le neveu d'Antonio da Ponte qui créa le pont du Rialto, le pont fut terminé en 1602.

Le nom romantique du pont est censé faire référence aux soupirs des condamnés qui voyaient Venise pour la dernière fois avant d'être emmenés vers leurs cellules de prison. En réalité, il était difficile de voir la ville au travers des grilles de pierre couvrant les fenêtres et la majorité des prisonniers de cette époque étaient de petits délinquants.

[« J'étais à Venise sur le pont des Soupirs; j'avais à ma droite un palais, à ma gauche une prison. »]

Lord Byron



Le pont des Soupirs

Le campanile de Saint-Marc

Le campanile de Saint-Marc (Campanile di San Marco) est l'une des structures les plus hautes de la ville et donc l'un des symboles les plus reconnaissables de Venise. Le visiteur y bénéficie d'une vue splendide sur la ville et la lagune ainsi que sur les Alpes italiennes au loin.

Le clocher haut de 98,6 m se tient seul dans le coin de la place Saint-Marc, près de l'entrée avant de la basilique. La structure en briques mesure 12 m de large de chaque côté et 50 m de haut, et est dominée par un clocher avec cinq cloches. Une flèche termine la tour avec une girouette dorée au sommet.

Si la conception du campanile date du XVI^e siècle, la tour elle-même fut totalement reconstruite en 1912 après l'écroulement de la tour d'origine en 1902. L'inauguration de la nouvelle tour a eu lieu exactement 1 000 ans après la pose des fondations de la tour d'origine.



Le campanile de Saint-Marc

La basilique Saint-Marc

La basilique Saint-Marc (Basilica di San Marco) est l'église la plus célèbre de Venise et le meilleur exemple de l'architecture italo-byzantine unique de la ville.

Construite pour abriter les reliques de saint Marc l'évangéliste, on sait peu de choses sur les bâtiments d'origine de l'église, mais la structure actuelle aurait été construite entre 1073 et 1093. La basilique a la forme d'une croix grecque et le plus haut des cinq dômes atteint 43 m de hauteur.

Si la disposition de l'église n'a pas été modifiée au fil des siècles, sa décoration intérieure et extérieure a beaucoup changé. L'implication de Venise dans les croisades et les conquêtes a fait que des mosaïques,

colonnes et frises venant de toute la Méditerranée ont été ajoutées à l'intérieur opulent en mosaïque dorée d'origine. La brique extérieure fut graduellement recouverte de revêtements et de sculptures en marbre alors que les bateaux vénitiens revenaient avec les butins de la guerre et du commerce.

Symbole de la richesse et du pouvoir de la République vénitienne, la basilique Saint-Marc reste aujourd'hui l'un des monuments les plus impressionnants de la ville.



La basilique Saint-Marc

Saint-Théodore et le Lion ailé de Saint-Marc

Deux colonnes de granit gardent l'entrée de la place Saint-Marc (Piazza di San Marco).

Sur le haut de la colonne de droite se trouve une statue de Saint-Théodore, le premier patron de la ville. Il tient une lance et son pied repose sur un crocodile, représentant le dragon qu'il aurait tué. Sur la colonne de gauche se trouve le Lion ailé de Venise, le symbole du deuxième patron de la ville, Saint-Marc.

On pense que les deux colonnes ont été érigées aux environs de 1268 et que la ville exécutait jadis les criminels condamnés entre les deux colonnes. Encore aujourd'hui, les Vénitiens superstitieux évitent de marcher entre ces deux colonnes.

[« Il est une cité glorieuse
dans la mer. Mer qui
emplit les rues et les
ruelles, affluant
et refluant... »]

Samuel Rogers



Saint-Théodore et le Lion ailé de Saint-Marc

Venecia

Construida sobre más de 100 islas en una laguna cenagosa a orillas del mar Adriático, Venecia posee un horizonte que emerge del agua, dando lugar a una experiencia arquitectónica incomparable. No hay carreteras ni autos en el centro histórico; en su lugar, 177 canales cruzados por más de 400 puentes ofrecen acceso a incontables callejones y plazuelas.

Aunque el origen de la ciudad se remonta a hace más de 1.500 años, la edad dorada de Venecia tuvo lugar durante la baja Edad Media y el Renacimiento, períodos durante los que se convirtió en una de las repúblicas más poderosas del Mediterráneo oriental.

Hoy, la ciudad enfrenta grandes desafíos, como su progresivo hundimiento, graves inundaciones y los problemas derivados de su popularidad como destino turístico. Más de 60.000 personas visitan Venecia a diario (cifra que supera su propia población), obligando a la ciudad a buscar una solución al dilema que supone acomodarlos y mantener su naturaleza e identidad únicas.



Puente de Rialto

El puente de Rialto (Ponte di Rialto) cruza el Gran Canal, en el corazón del centro histórico. Construido entre 1588 y 1591, se construyó para sustituir varios puentes de madera que unieron los distritos de San Marco y San Polo durante el siglo XII.

Cuando el último puente de madera se derrumbó en 1524, se contemplaron varias posibilidades antes de que las autoridades de la ciudad decidiesen construir un puente de piedra en 1551. El arquitecto Antonio da Ponte tuvo que competir con ilustres oponentes, como Miguel Ángel y Palladio, antes de hacerse con el contrato.

Su diseño, un puente con un solo ojo de 7,5 m de longitud, incluía tres pasarelas: dos por los lados exteriores, y otra central, más amplia, entre dos hileras de pequeños comercios. La estructura se construyó sobre unos 12.000 pilotes de madera que todavía hoy, más de 400 años después, soportan el peso del puente.

[«Construir una ciudad donde es imposible hacerlo es una locura en sí misma; pero construir una de las ciudades más elegantes y majestuosas del mundo en ese mismo lugar es una locura colosalmente genial».]

Alexander Herzen



Puente de Rialto

Puente de los Suspiros

El puente de los Suspiros (Ponte dei Sospiri) es un puente cubierto construido en piedra caliza blanca que cruza el Rio di Palazzo, conectando la prisión de la ciudad antigua con las salas de interrogatorio del Palacio Ducal. Diseñado por Antonio Contino, sobrino de Antonio da Ponte (responsable del puente de Rialto), el puente se completó en 1602.

Se cree que su romántico nombre hace referencia a los suspiros que arrojaban los convictos al contemplar Venecia por última vez antes de ser conducidos a sus celdas. En realidad, no se puede ver mucho a través de las celosías de piedra que cubren las ventanas, y la mayor parte de los prisioneros de la época eran criminales de poca envergadura.

[«Estuve en Venecia, en el puente de los Suspiros, con un palacio y una prisión a cada lado».]

Lord Byron



Puente de los Suspiros

Campanario de San Marcos

Una de las estructuras más altas de la ciudad, el campanario de San Marcos (Campanile di San Marco) es uno de los símbolos más populares de Venecia. Desde aquí, el visitante puede tener unas increíbles vistas sobre la ciudad y la laguna, llegando incluso a divisar los Alpes italianos en la distancia.

La torre, de 98,6 m de altura, se encuentra en una de las esquinas de la plaza de San Marcos, cerca de la entrada a la basílica. La estructura de mampostería posee 12 m de lado y 50 m de altura; sobre ella se asienta el campanario, con cinco campanas. Un remate con una veleta dorada corona la torre.

Aunque el diseño del campanario es del siglo XVI, la torre fue reconstruida por completo en 1912, después de que la original se derrumbase en 1902. La inauguración de la nueva torre tuvo lugar exactamente 1.000 años después de que se colocara la primera piedra de la torre original.



Campanario de San Marcos

Basílica de San Marcos

La basílica de San Marcos (Basílica di San Marco) es la iglesia más famosa de Venecia y el mejor ejemplo de la extraordinaria arquitectura italo-bizantina de la ciudad.

Construida expresamente para alojar las reliquias de San Marcos Evangelista, poco se sabe de su aspecto original, aunque se cree que la actual estructura data de entre 1073 y 1093. La planta de la basílica responde a la forma de una cruz griega y la más alta de las cinco cúpulas posee una altura de 43 m.

Aunque la iglesia en sí no ha cambiado a lo largo de los siglos, su decoración interior y exterior sí lo ha hecho, y mucho. La participación de Venecia en cruzadas y conquistas dio lugar a la incorporación de mosaicos, columnas y frisos de todos los rincones del

Mediterráneo al opulento mosaico de oro que adornaba originalmente su interior. La mampostería exterior se cubrió progresivamente de mármol y tallas conforme los buques venecianos volvían con botines de guerra y el fruto de sus actividades comerciales.

Símbolo de la riqueza y el poder de la República de Venecia, la basílica de San Marcos sigue siendo uno de los monumentos más importantes de la ciudad.



Basilica di San Marco

Columnas de San Teodoro y el león de Venecia

Dos columnas de granito guardan la entrada de la plaza de San Marcos (Piazza di San Marco).

En lo alto de la columna oeste hay una estatua de San Teodoro, el primer patrón de la ciudad. Sostiene una lanza y tiene un pie apoyado sobre un cocodrilo que representa el dragón que, según se dice, asesinó. En la columna este se encuentra el león alado de Venecia, símbolo del segundo patrón de la ciudad: San Marcos.

Se cree que ambas columnas se erigieron alrededor de 1268 y que la ciudad celebraba la ejecución de criminales convictos entre ellas en la antigüedad. Hoy, los venecianos más supersticiosos evitan caminar entre el par de columnas.

[«Hay una ciudad gloriosa
en el mar. El mar está
en sus numerosos
callejones, con sus
mareas y corrientes [. . .]».]

Samuel Rogers



Columnas de San Teodoro y el león de Venecia

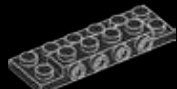

1x

1

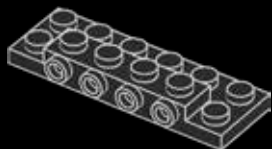

1x

2

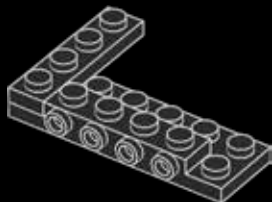

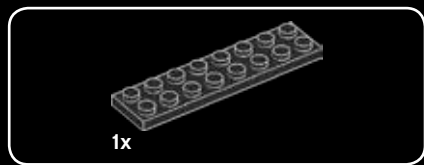

3

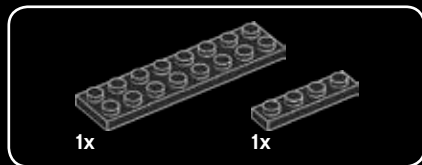
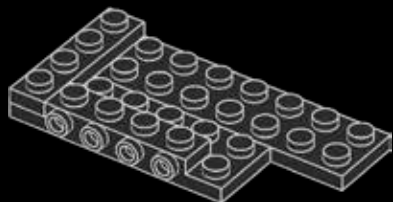

4

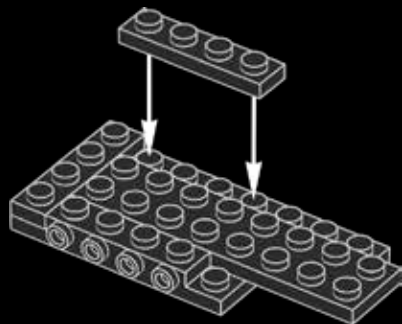



1x

5

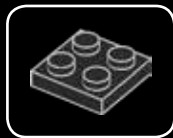
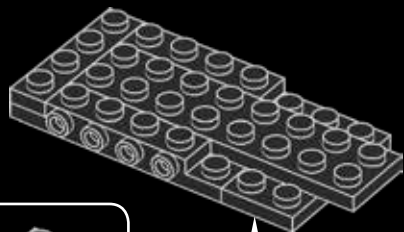

1x

6

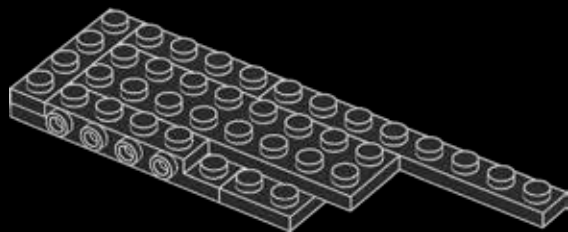

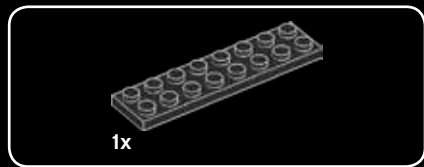

7

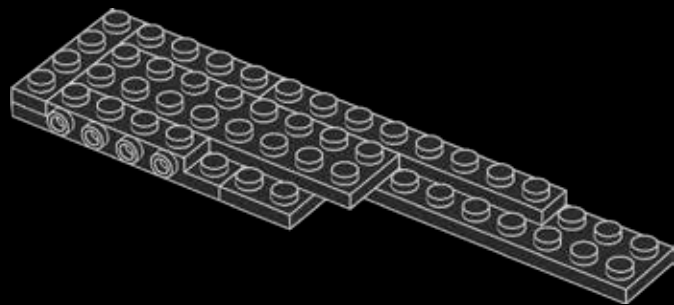

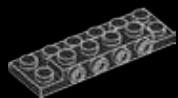

1x

8

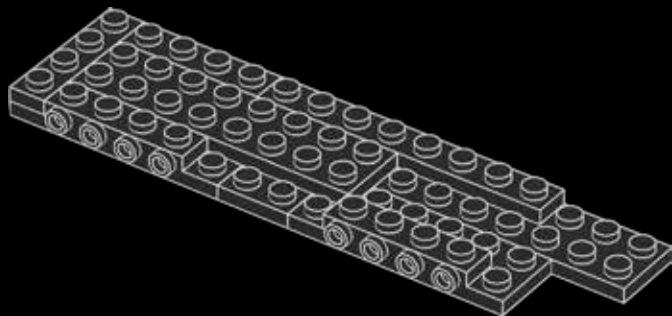



1x



1x



1x

9

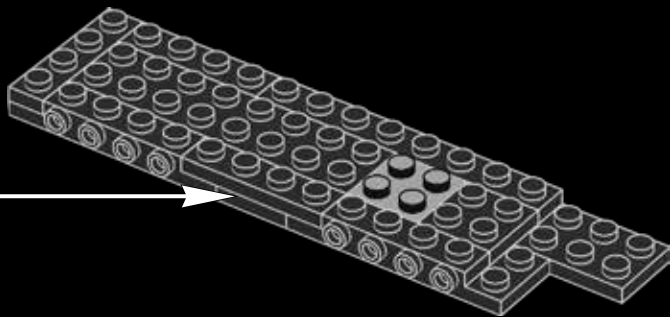
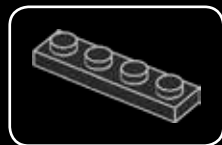

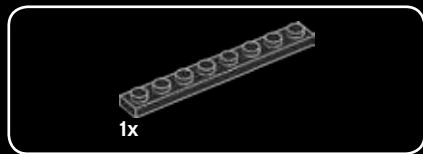

10

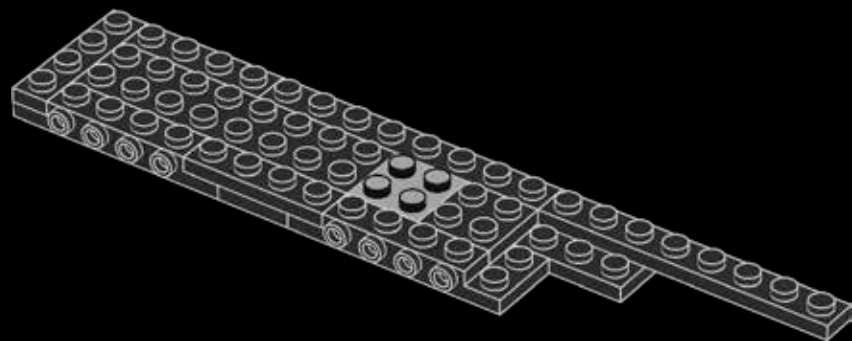

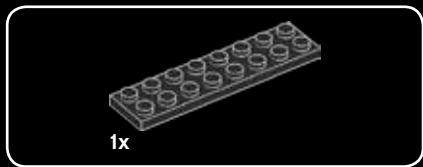

11

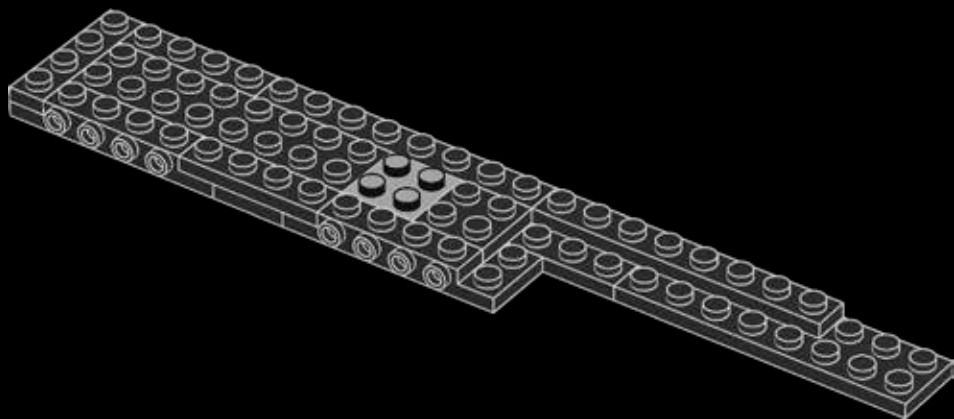

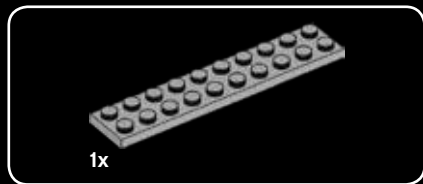

12

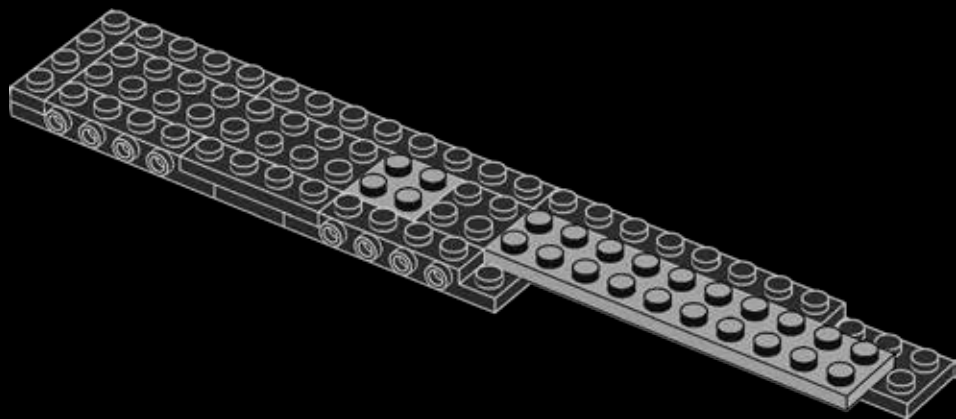

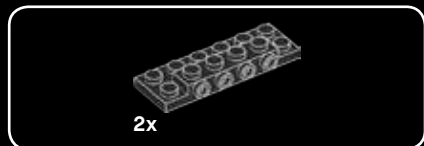

13

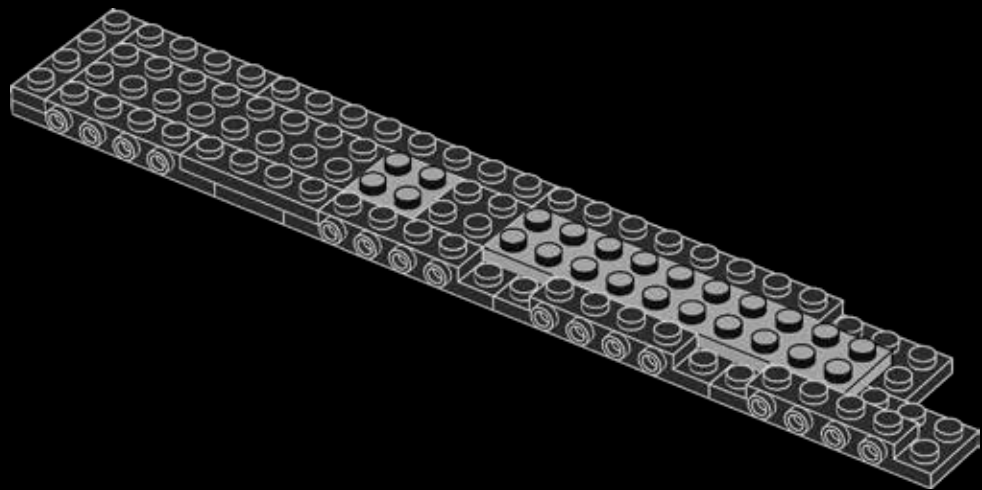



2x

14

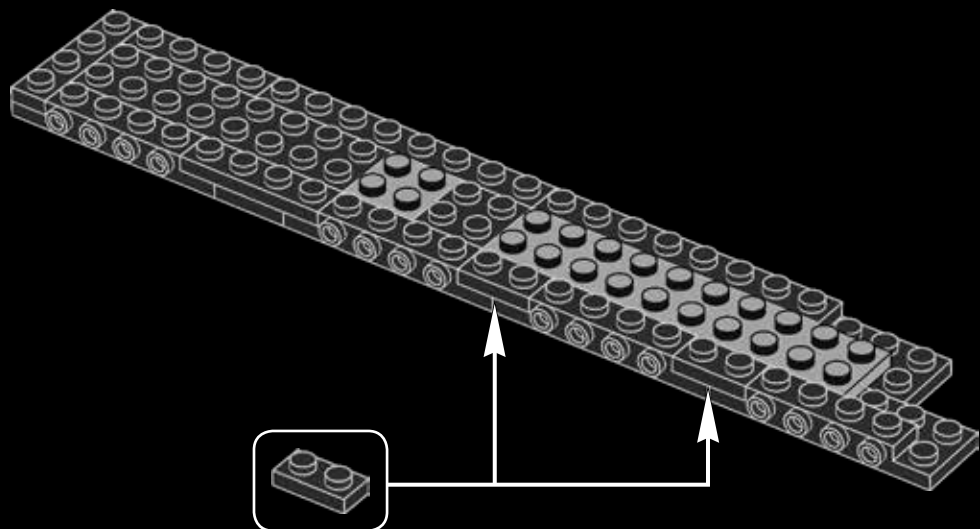



1x

As many of the small islands in the lagoon were spongy marshland, the majority of buildings sit upon a foundation of wooden piles.

Beaucoup des petites îles de la lagune étant des marécages spongieux, la plupart des bâtiments reposent sur une fondation de pilotis en bois.

Dado que muchos de los islotes de la laguna eran cenagosos, casi todos los edificios están construidos sobre pilotes de madera.



© Kite_rin

15

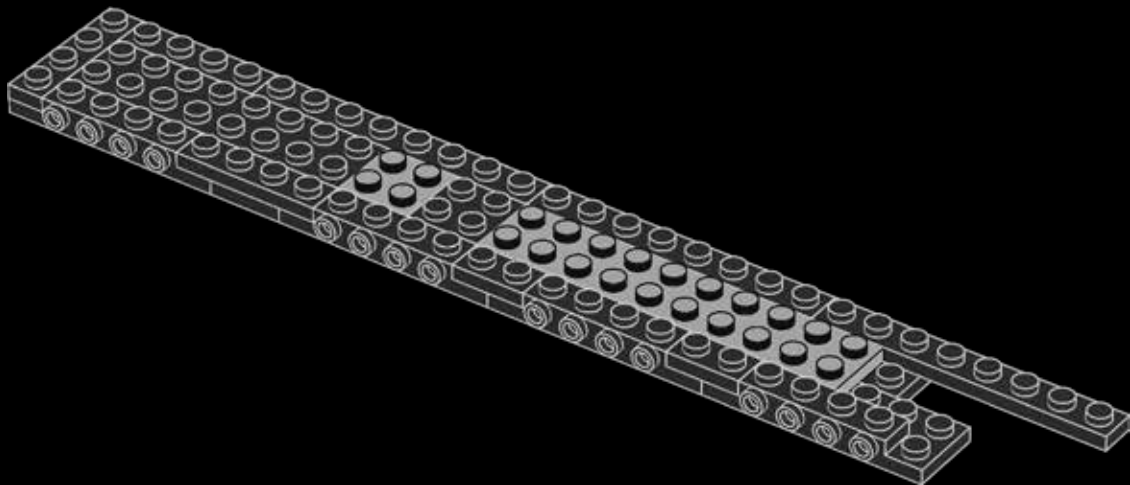

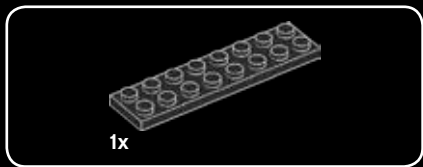

16

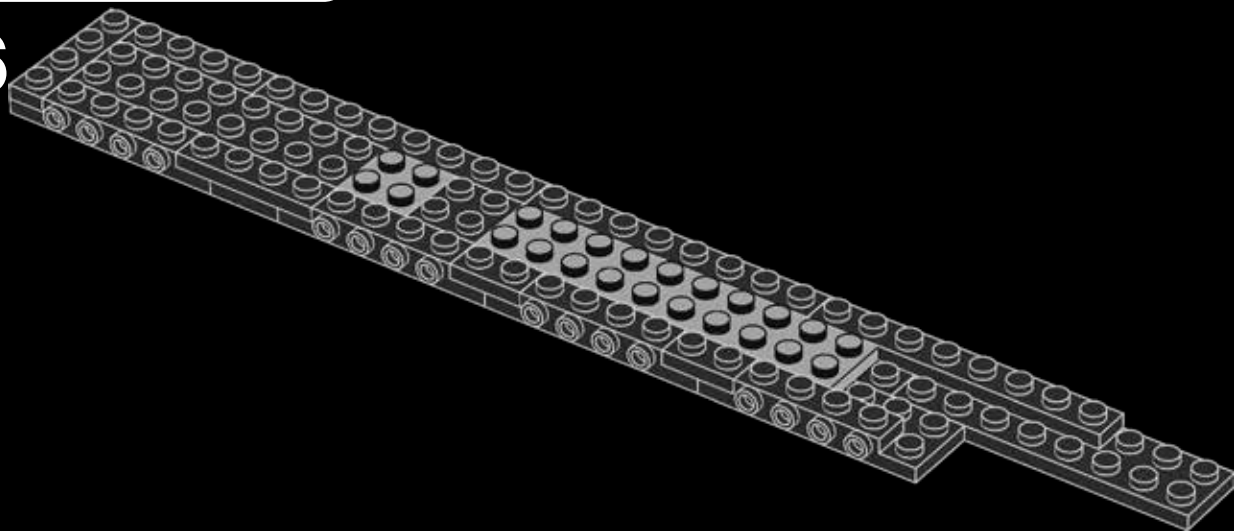

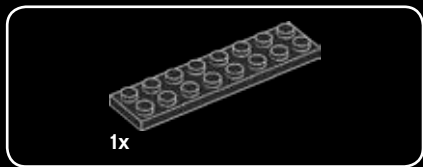

17

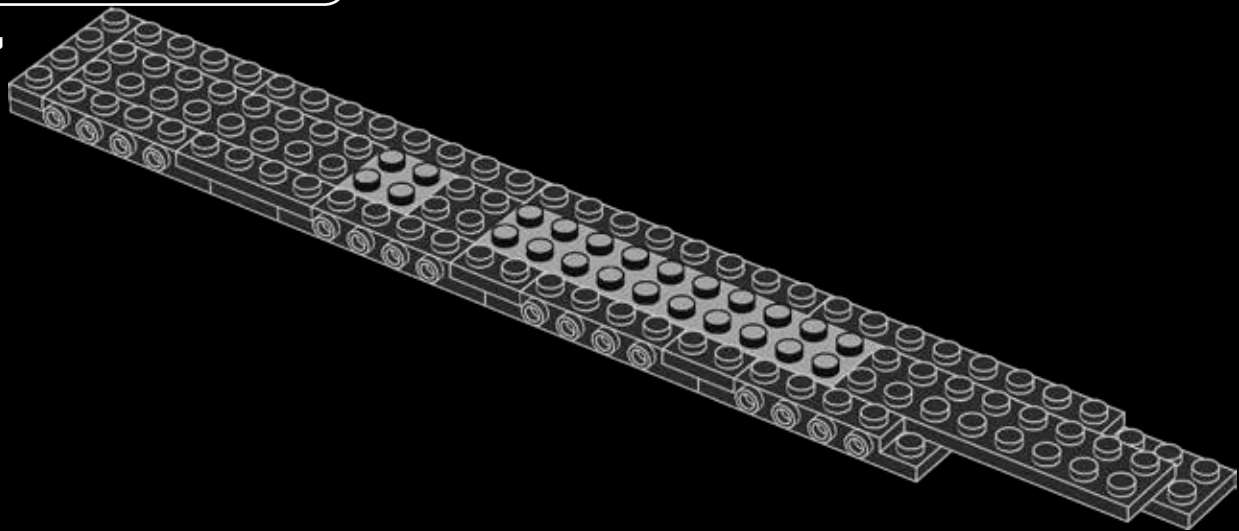

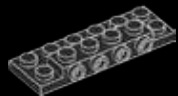

1x

18

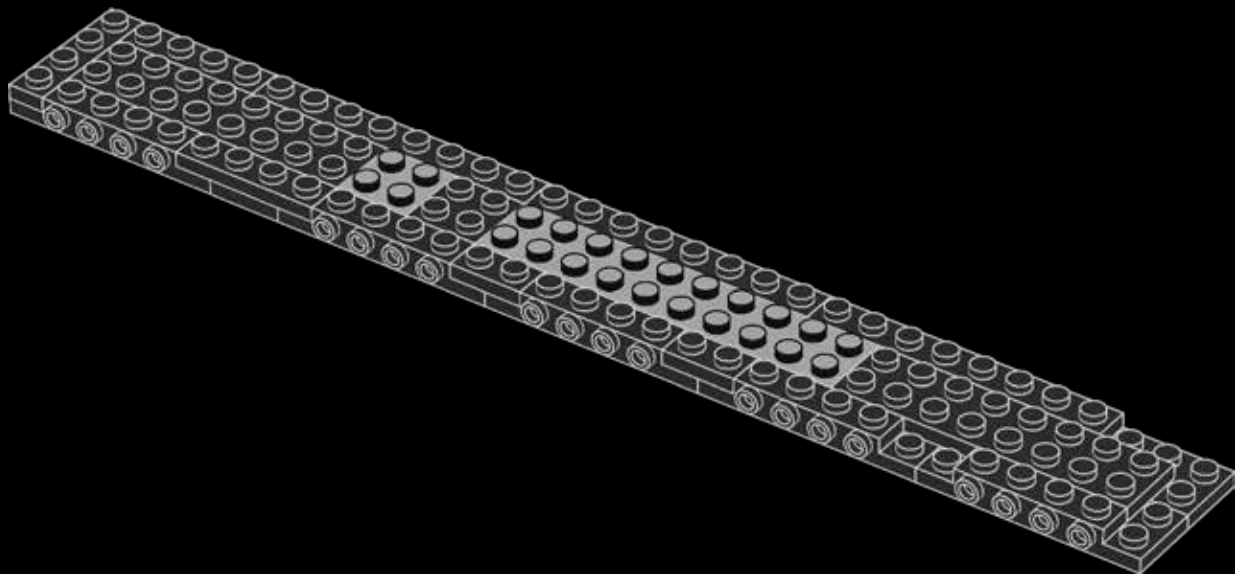



2x



1x

19

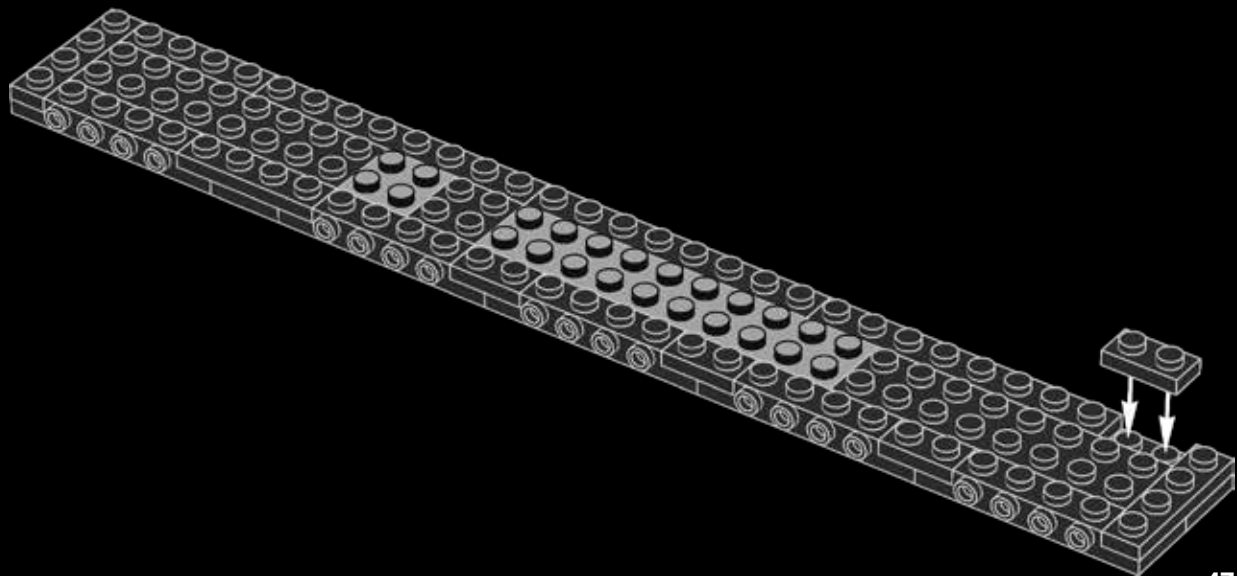



1x

20

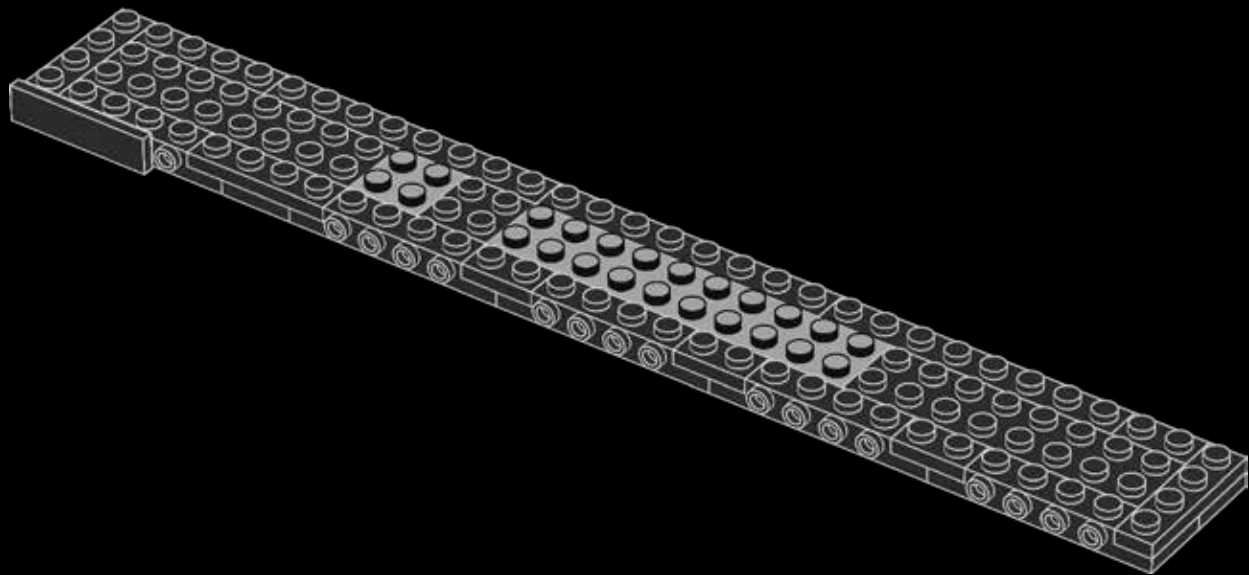

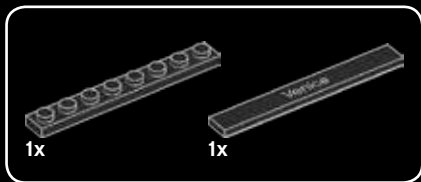

21

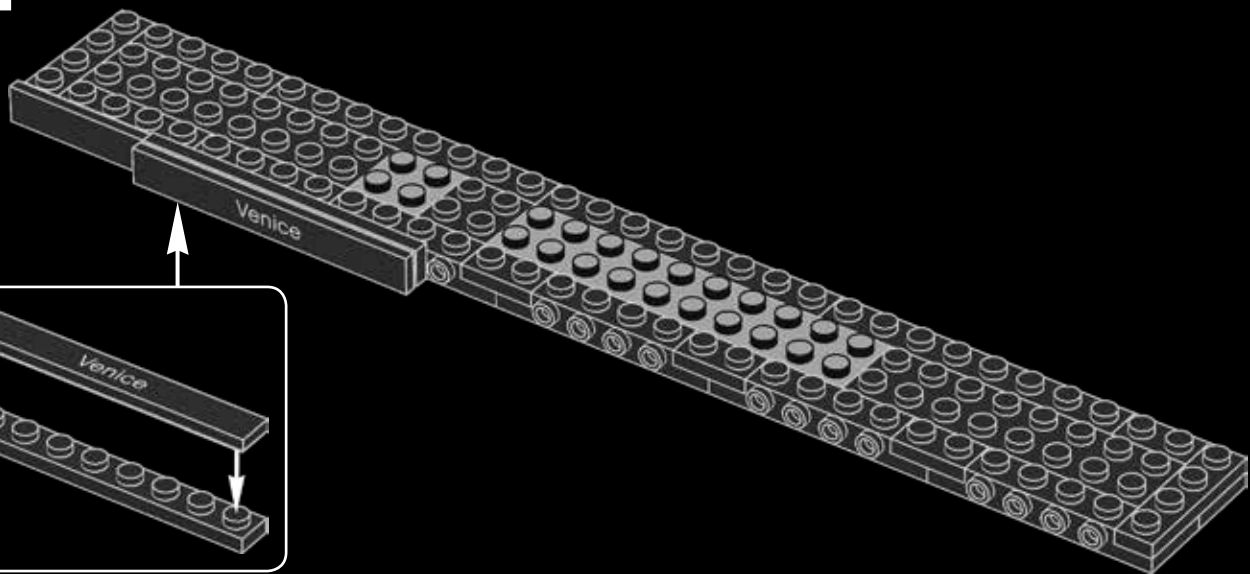
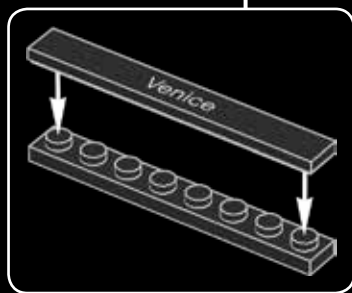

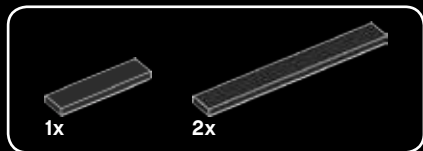

22

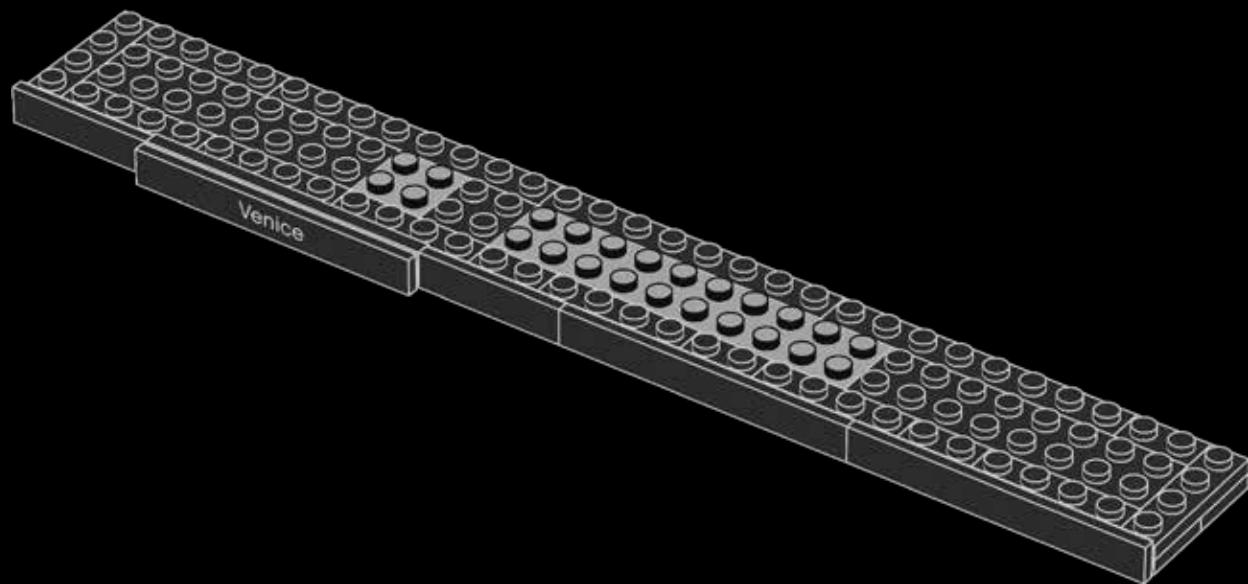

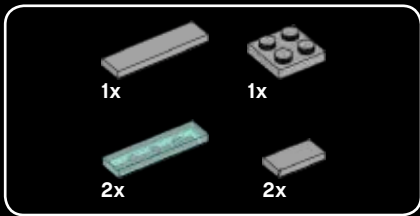

During the Acqua Alta (high water) tides can rise up to 6 ft. (2 m) and often flood St. Mark's Square.

Pendant l'Acqua Alta (hautes eaux), les marées peuvent monter de 2 m et souvent inonder la place Saint-Marc.

Cuando la marea está alta (acqua alta) el nivel del agua puede crecer hasta 2 m, inundando con frecuencia la plaza de San Marcos.



© BlueMoonStore

23

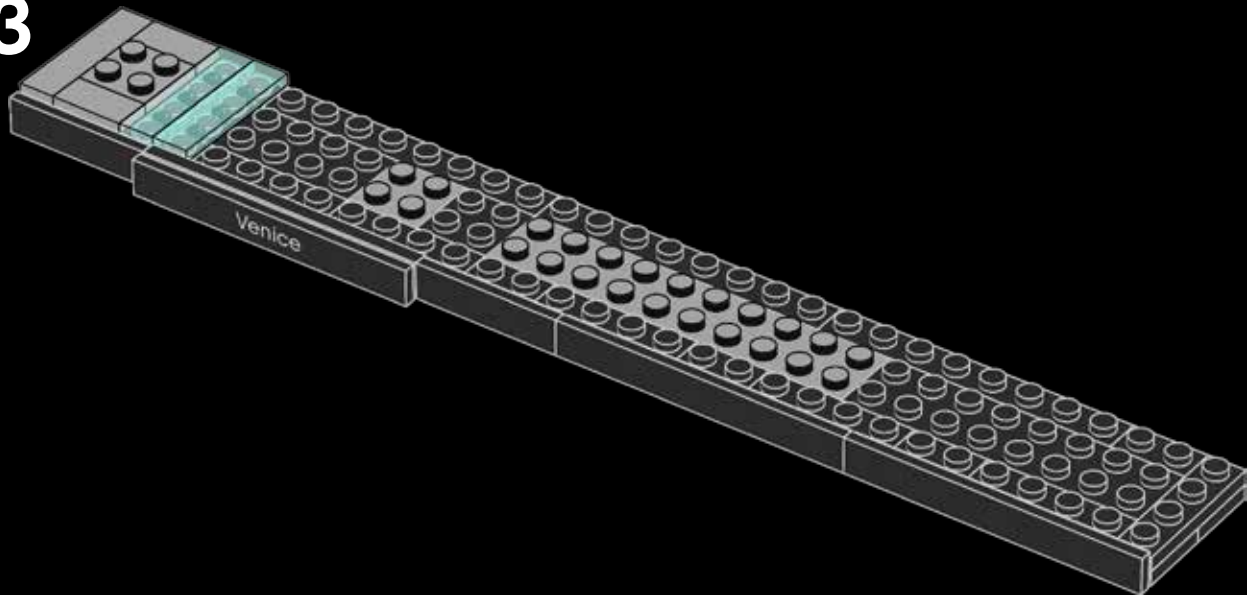

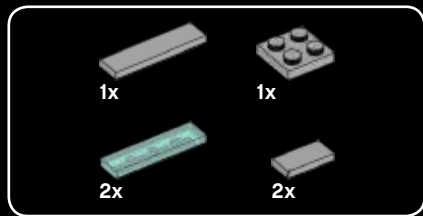

24

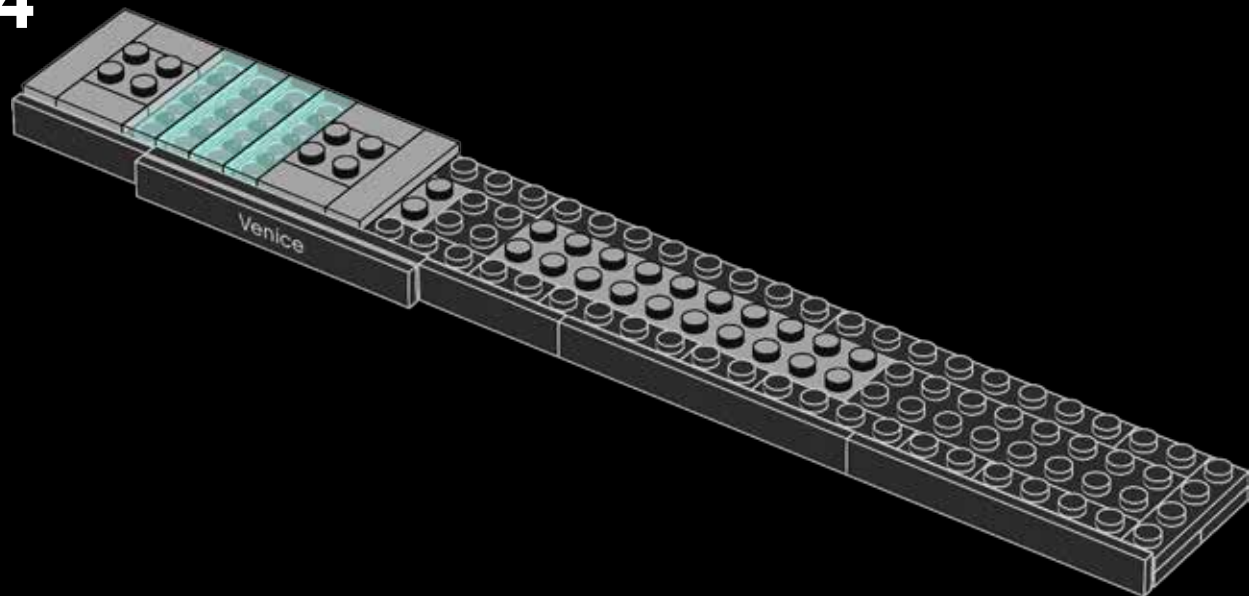

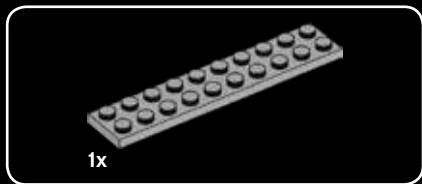

25

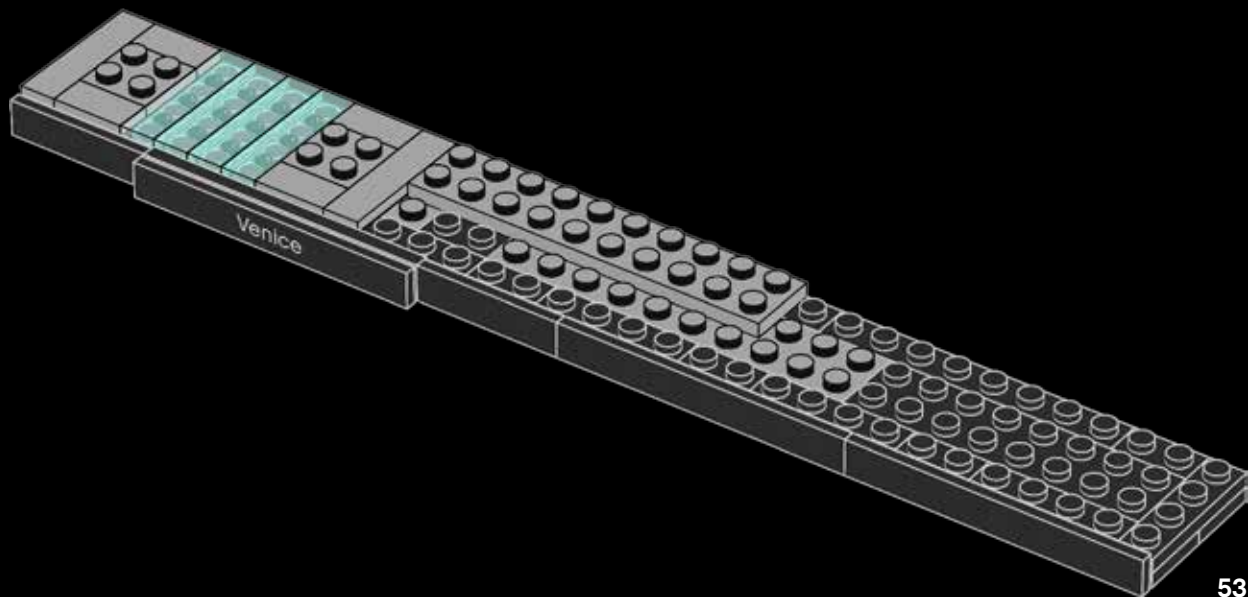

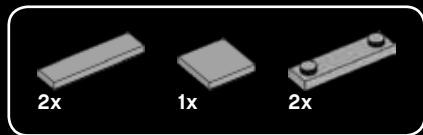

26

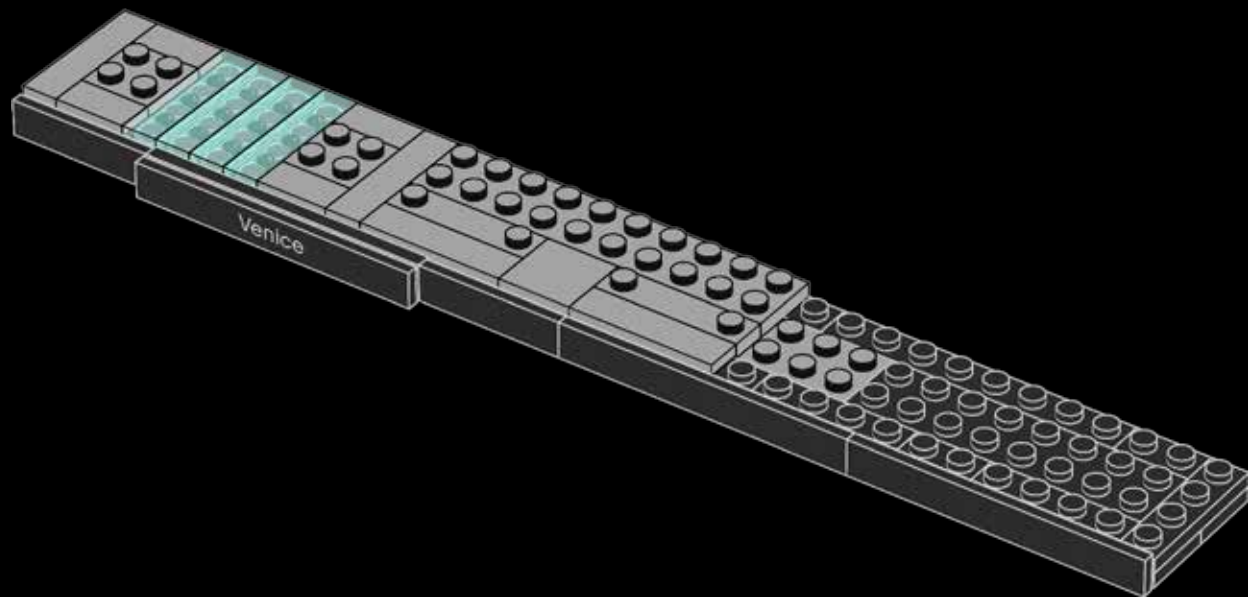

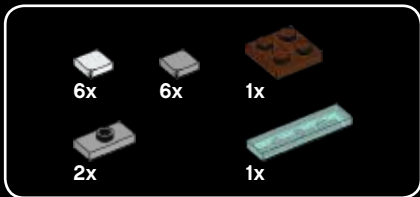

Venice is slowly sinking at the rate of about 0.04 inches (1-2 mm) every year.

Venise s'affaisse lentement à une vitesse d'environ 1 à 2 mm chaque année.

Venecia se hunde entre 1 y 2 mm cada año.



© pic3

27

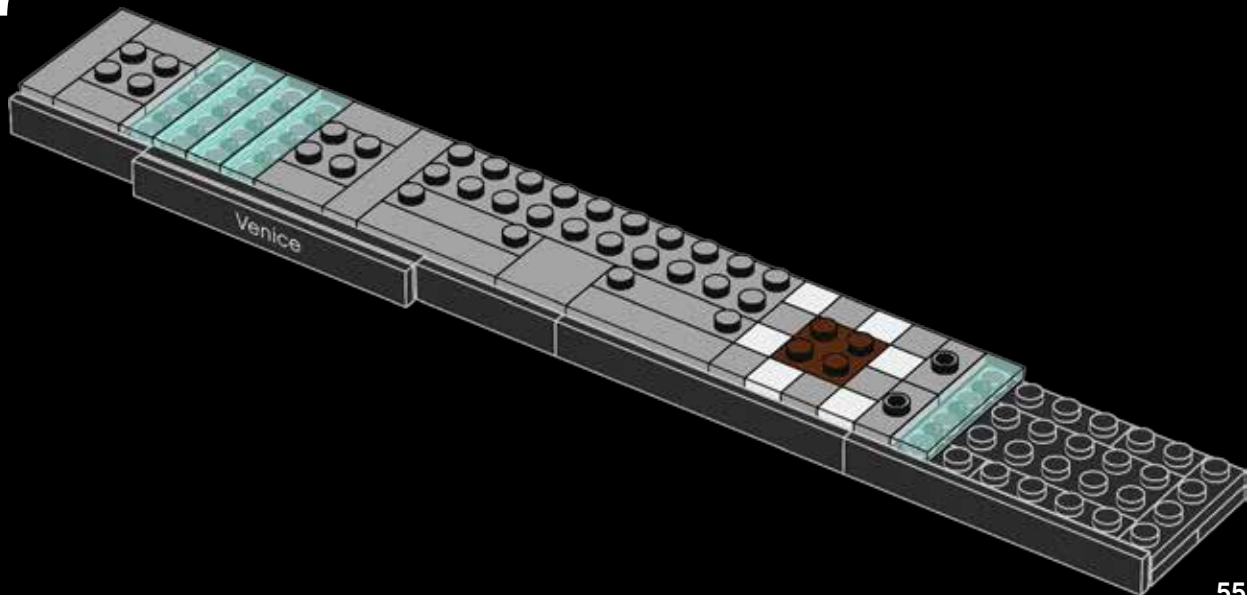



2x



2x



4x

28

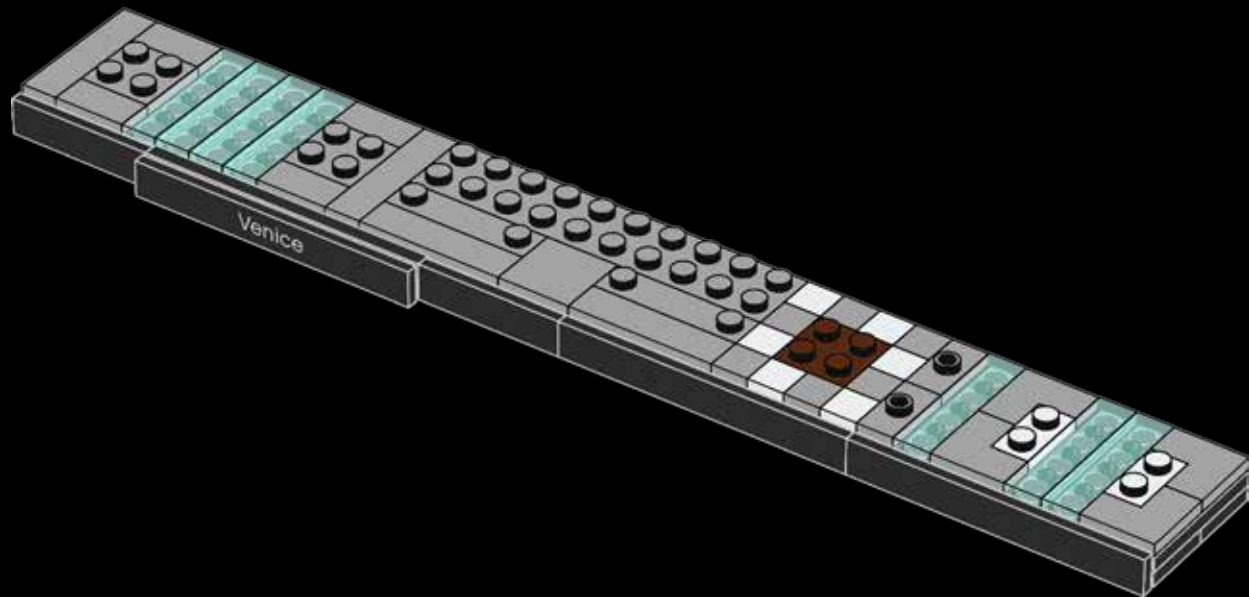



29

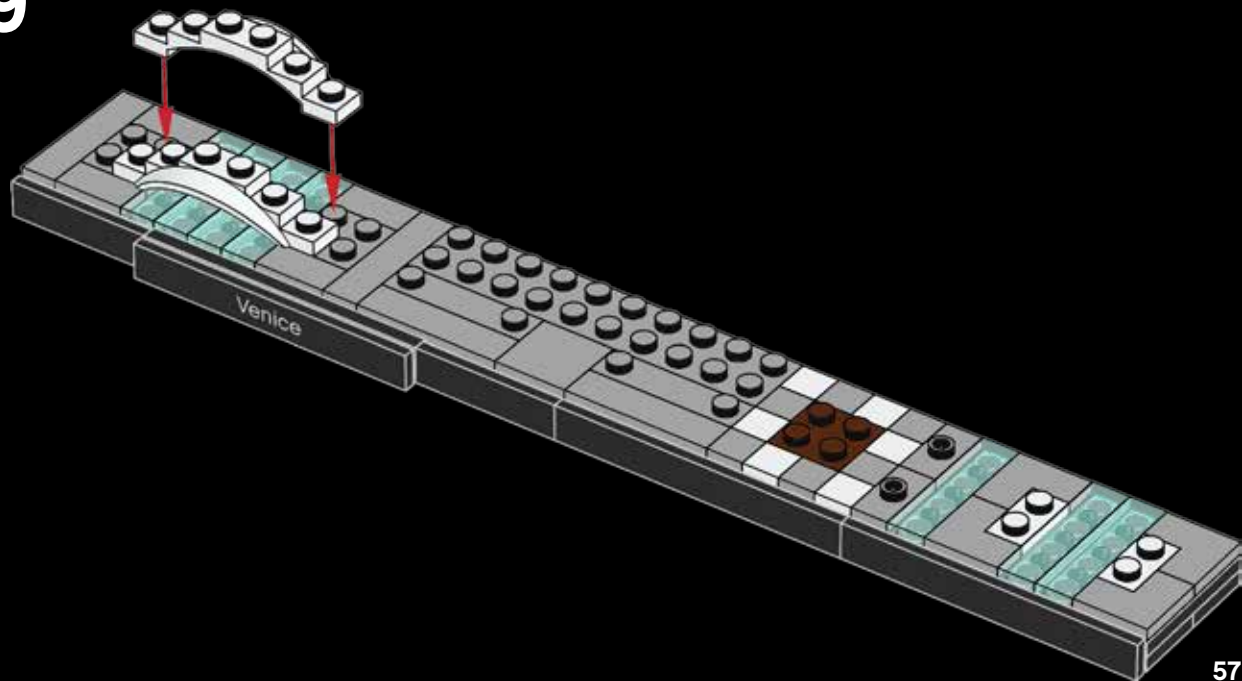



1x



6x

30

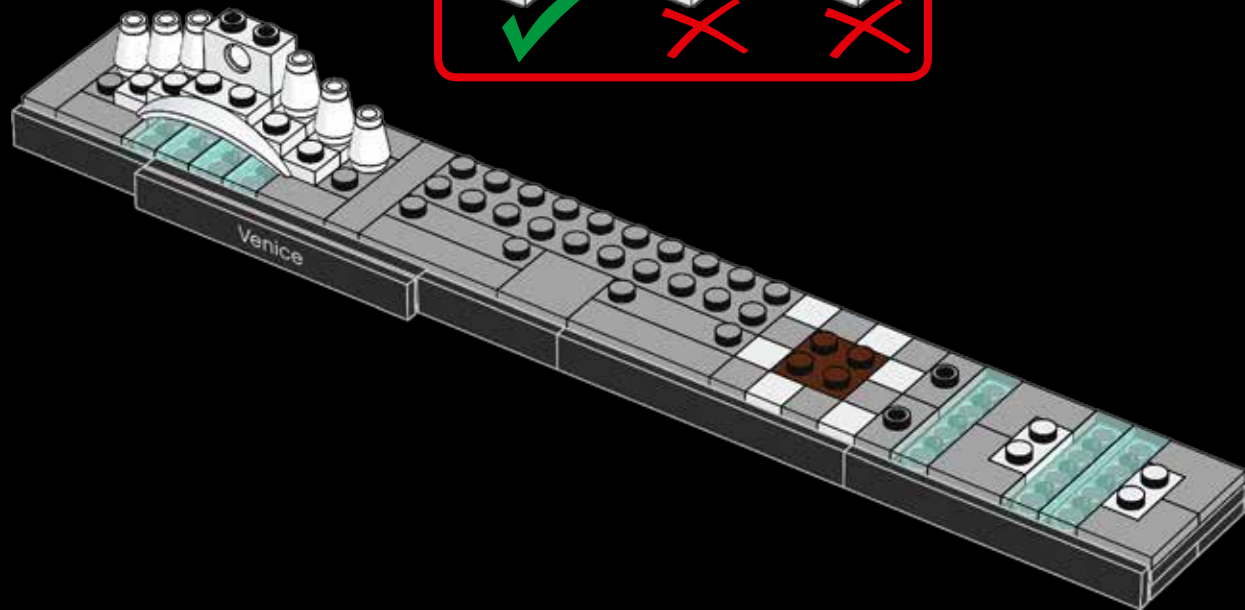



1x



6x

31

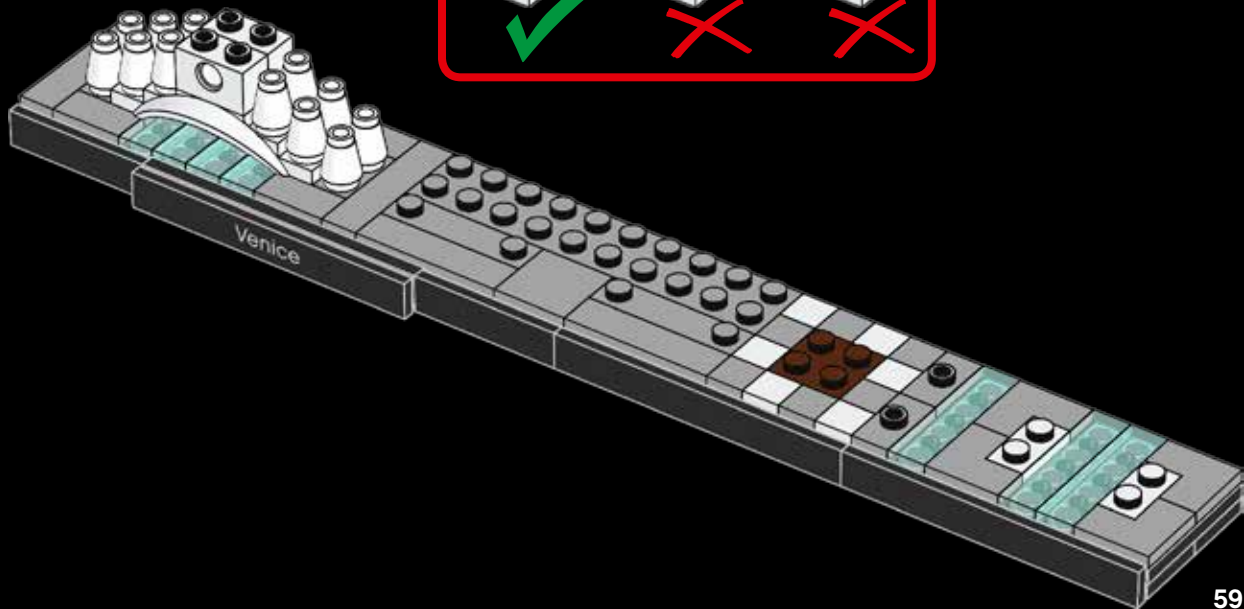



6x

32

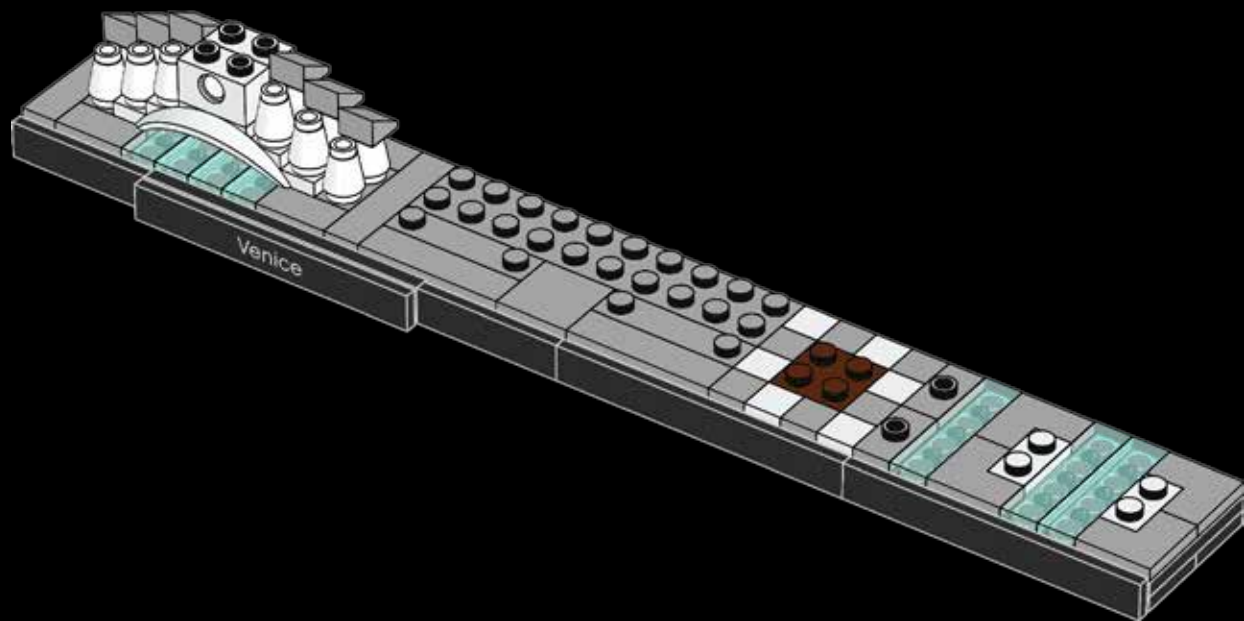



6x

33

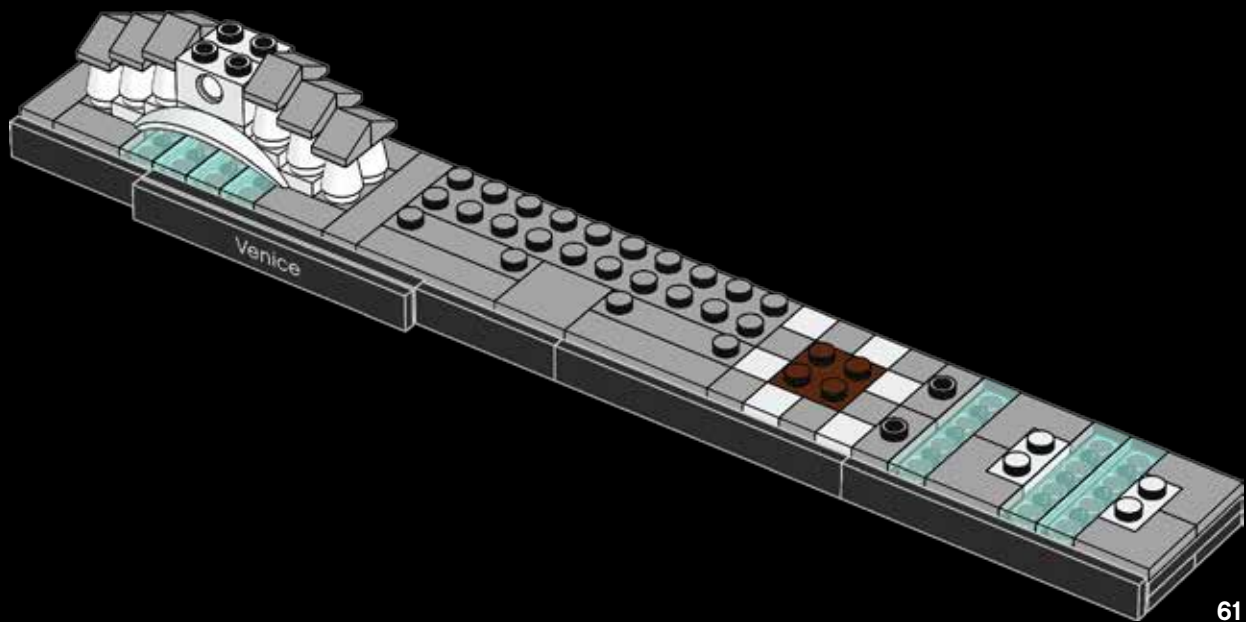



4x

34

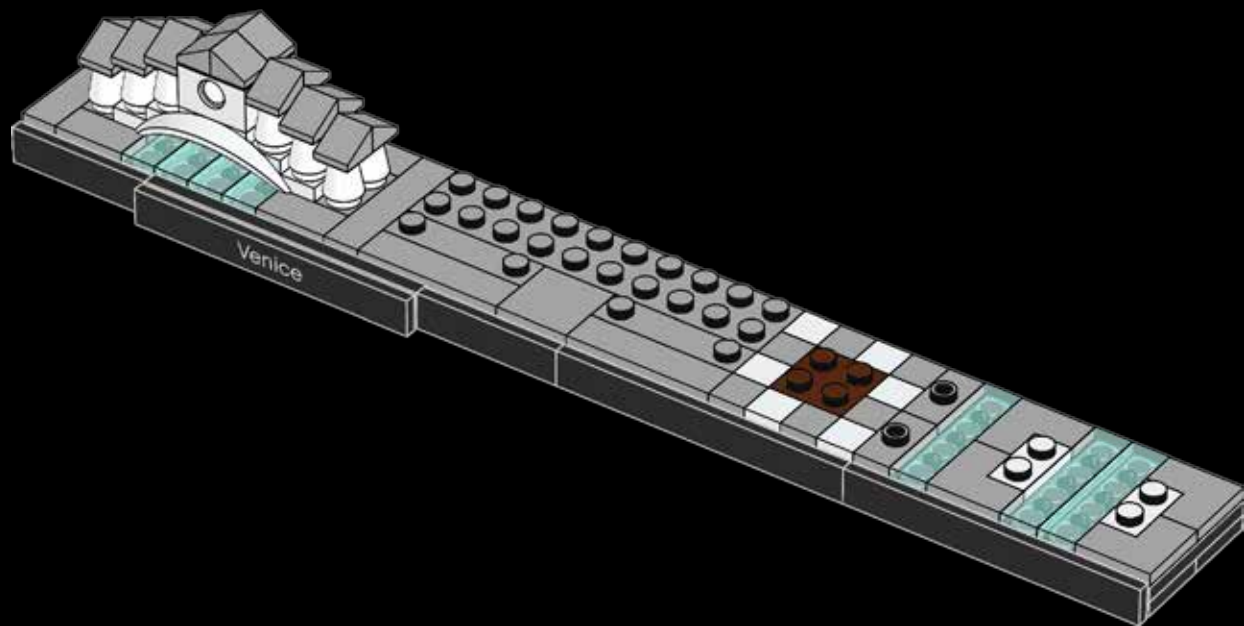



2x

The Grand Canal is the region's largest canal. Possessing a unique S-shape, it splits the city in half.

Le Grand Canal est le plus grand de la région. Doté d'une forme en S unique, le canal sépare la ville en deux.

El Gran Canal es el más grande de la región. Con su característica forma de S, divide la ciudad por la mitad.



© TTStudio

35

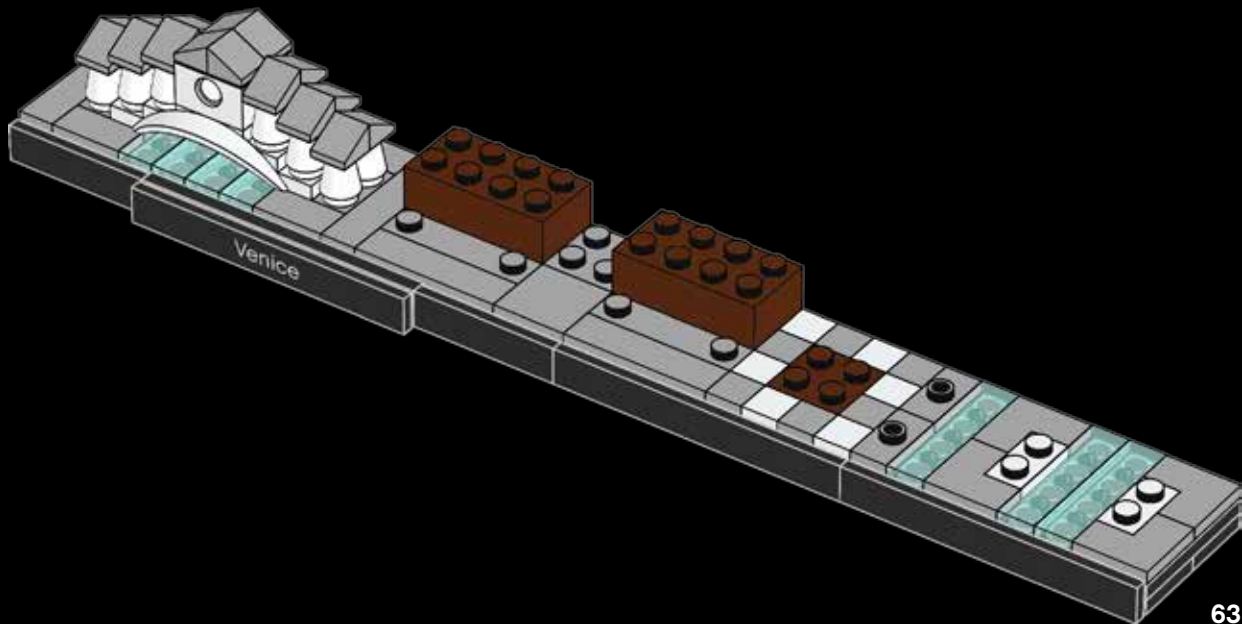



2x

36

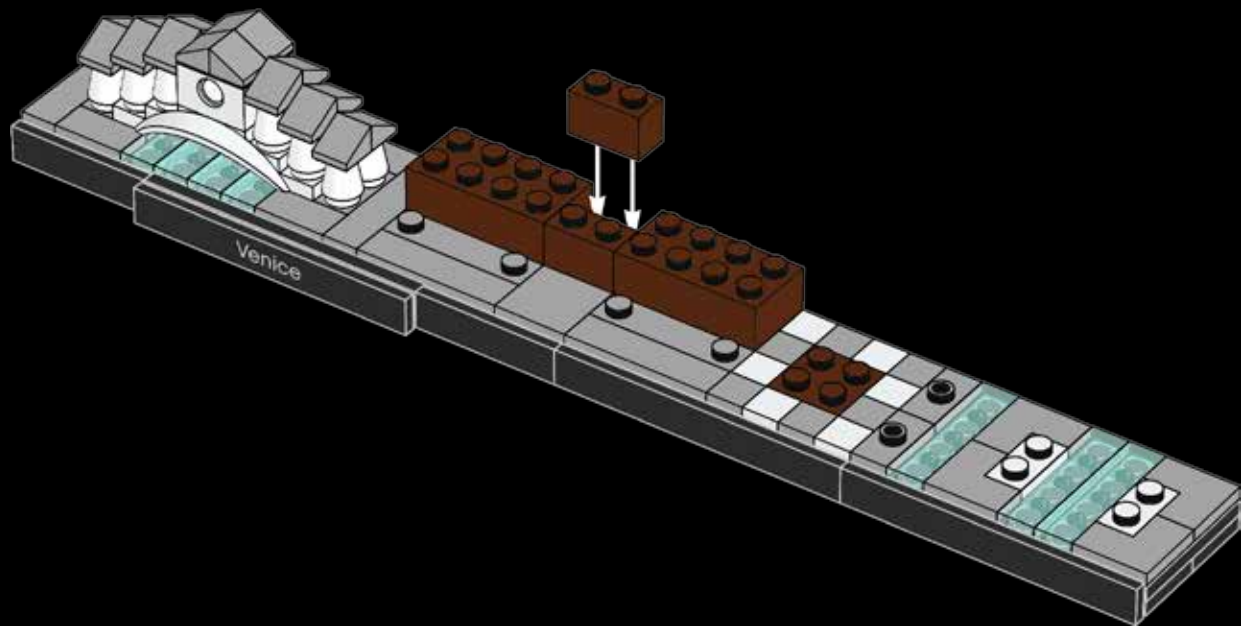



2x



2x

37

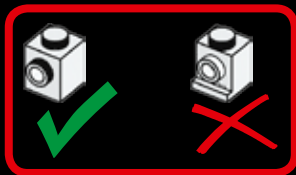
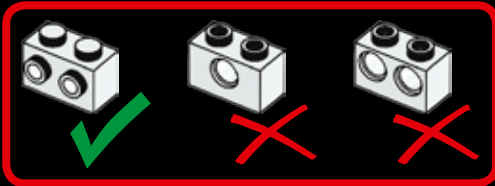
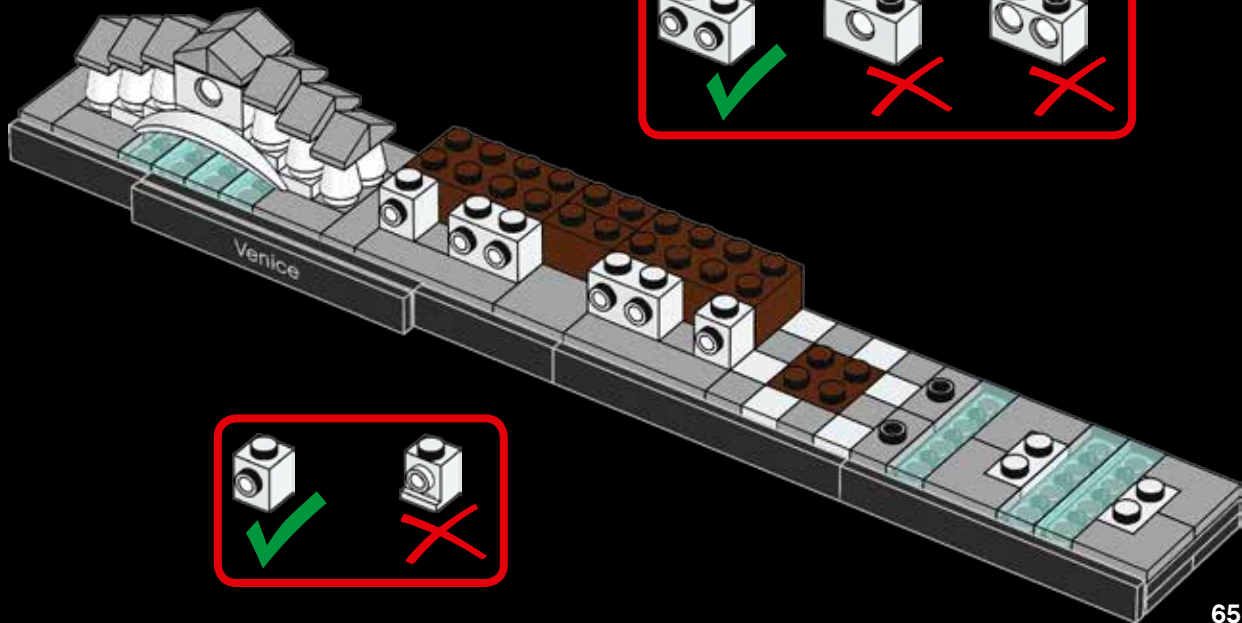



1x



2x

38

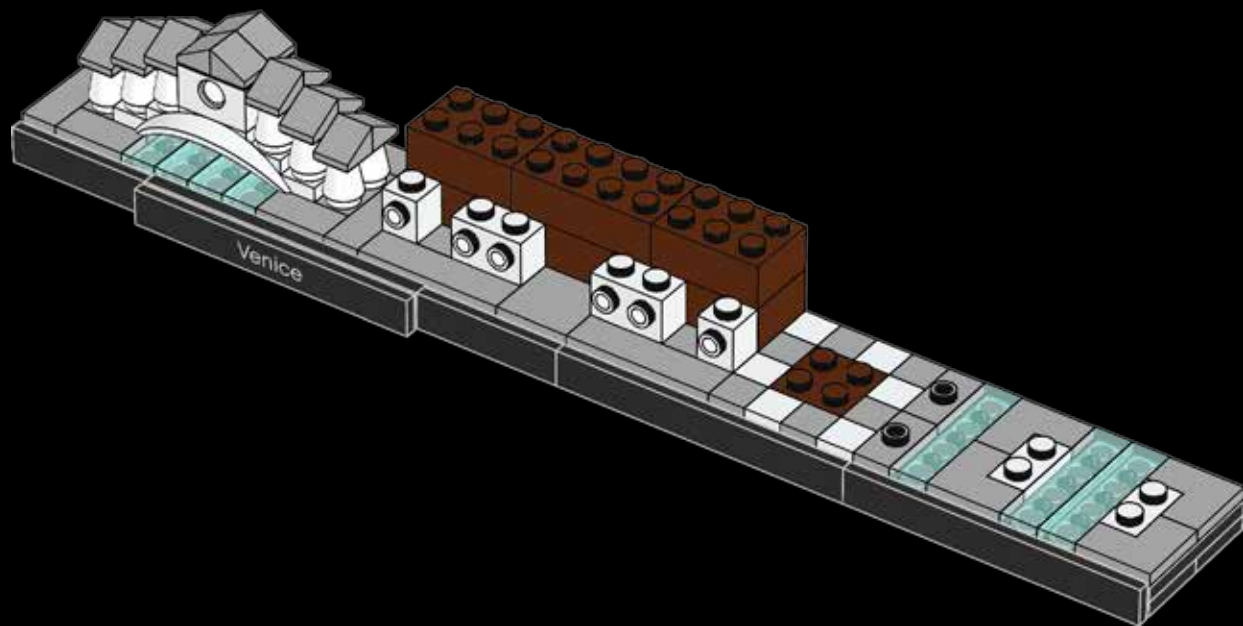

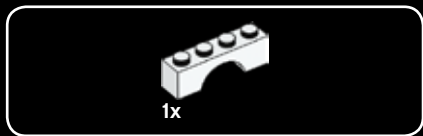

39

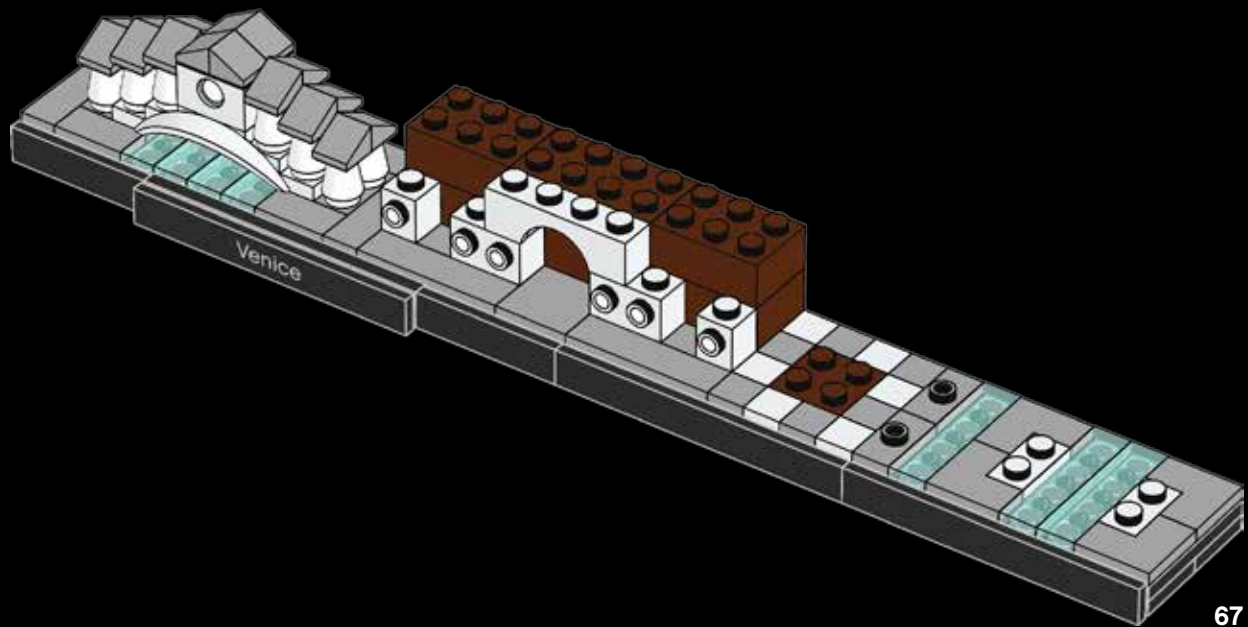



2x

40

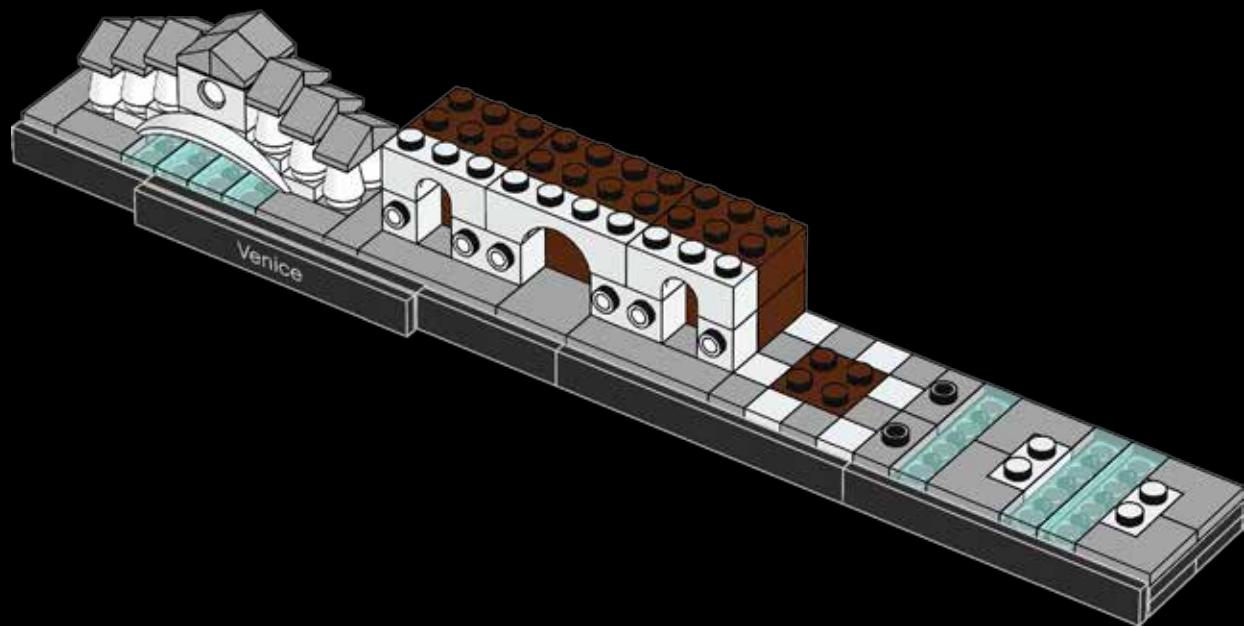

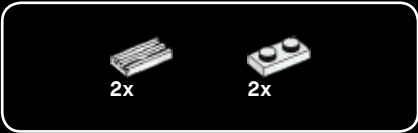

41

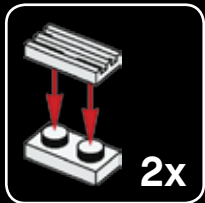
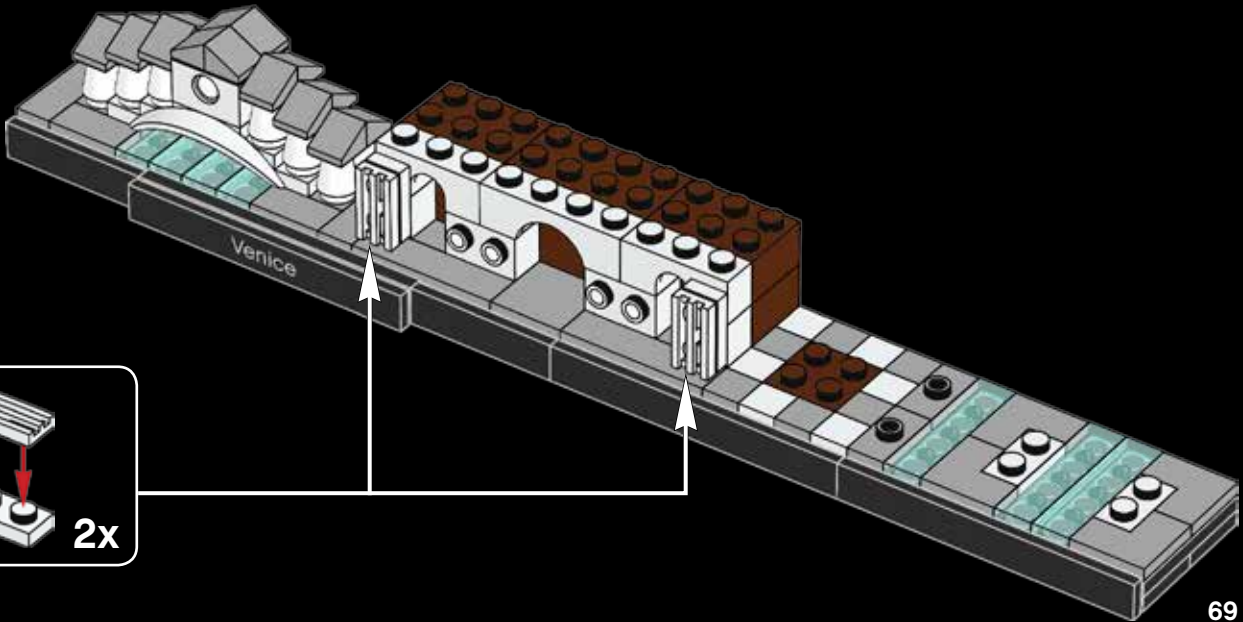



42

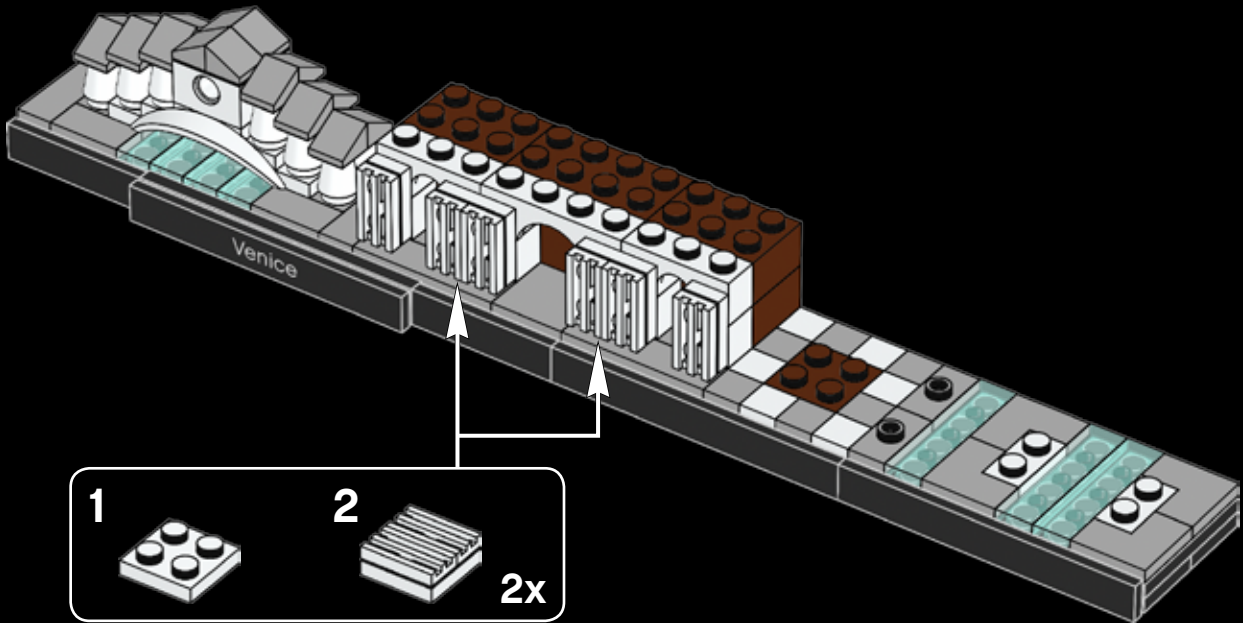

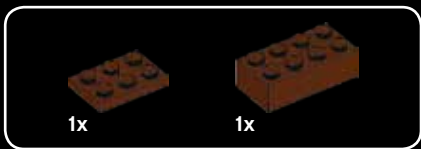

1

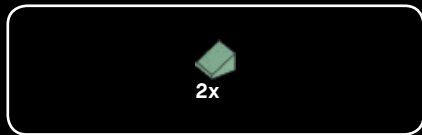
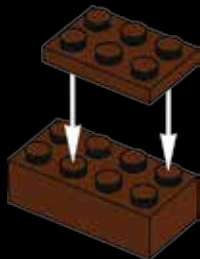

2

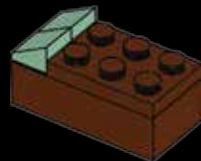



1x



2x

3



1x



1x

4



43

Venice has over 450 palaces and major buildings built in a mixture of styles: Gothic, Byzantine, Baroque etc.

Venise a plus de 450 palais et grands bâtiments construits dans un mélange de styles gothique, byzantin, baroque, etc.

Venecia posee más de 450 palacios y grandes edificios de diferentes estilos: gótico, bizantino, barroco, etc.



© Iakov Kallinin

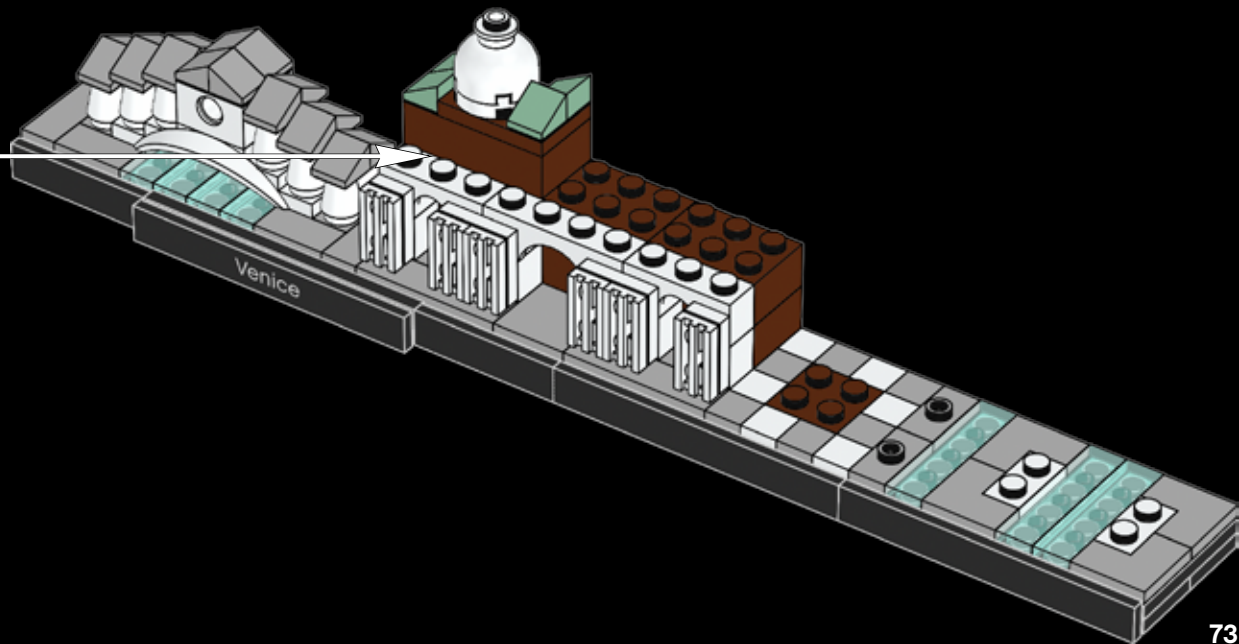

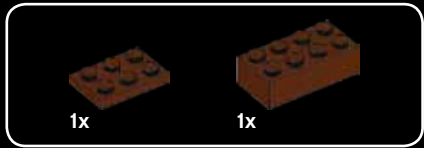

1

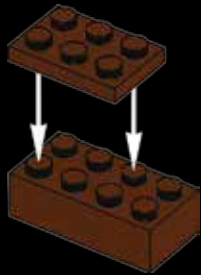

2





1x



2x

3



1x



1x

4



44

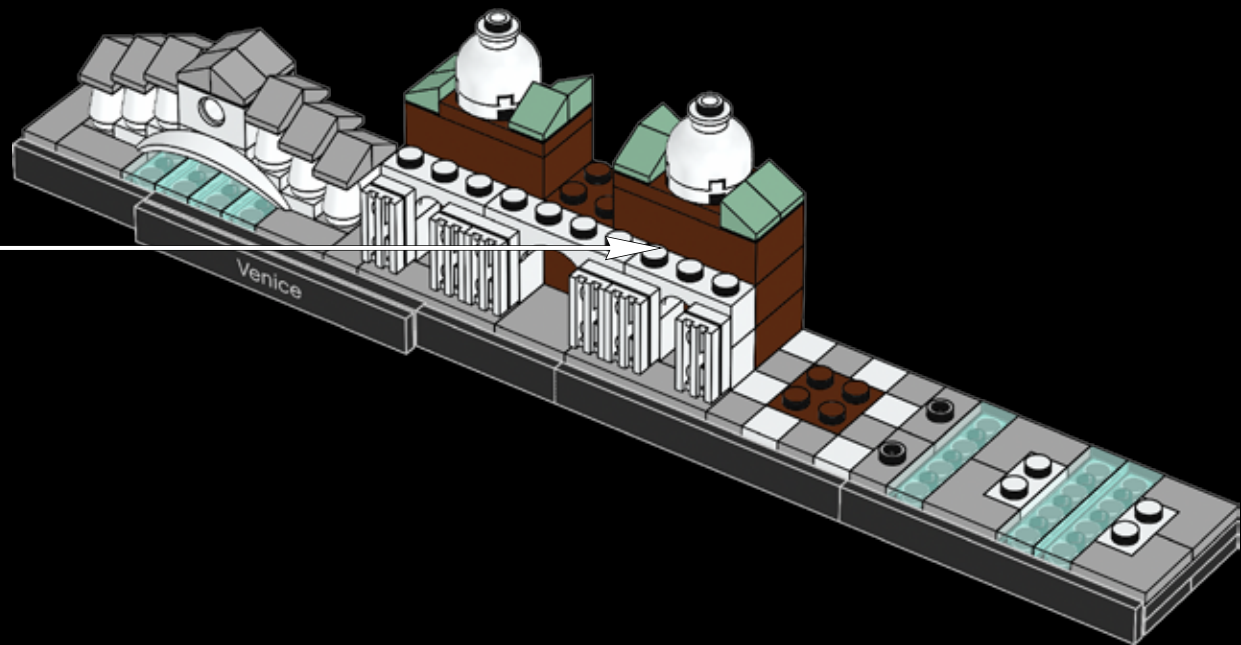



1x

45

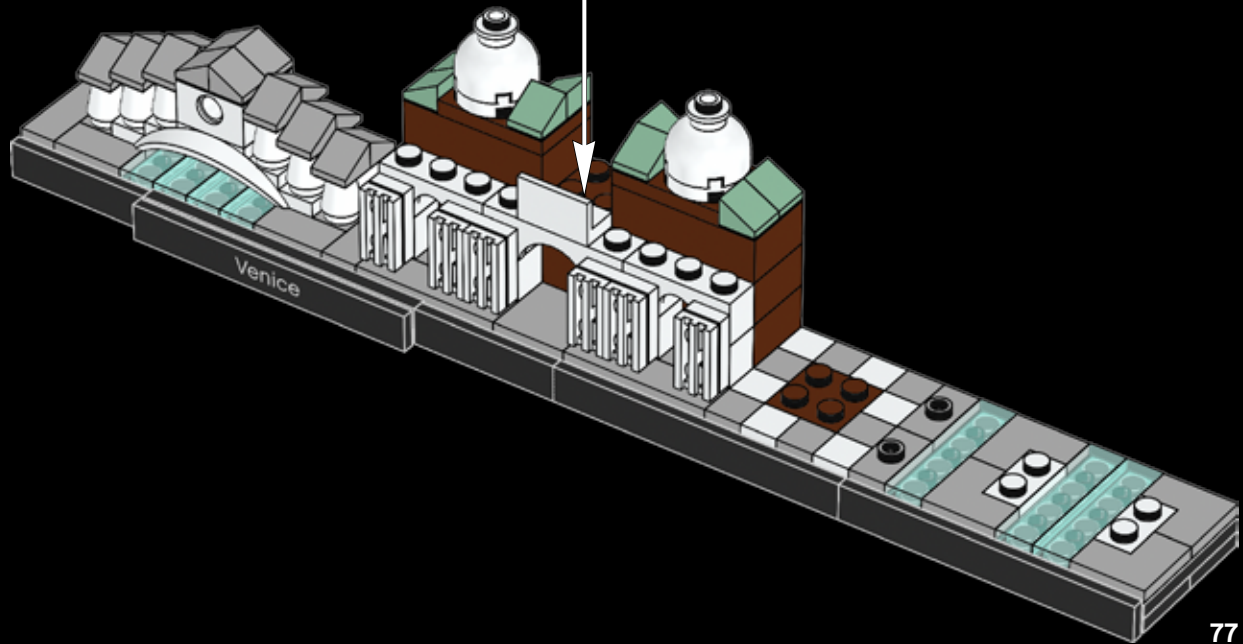



46

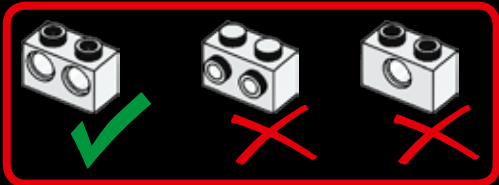
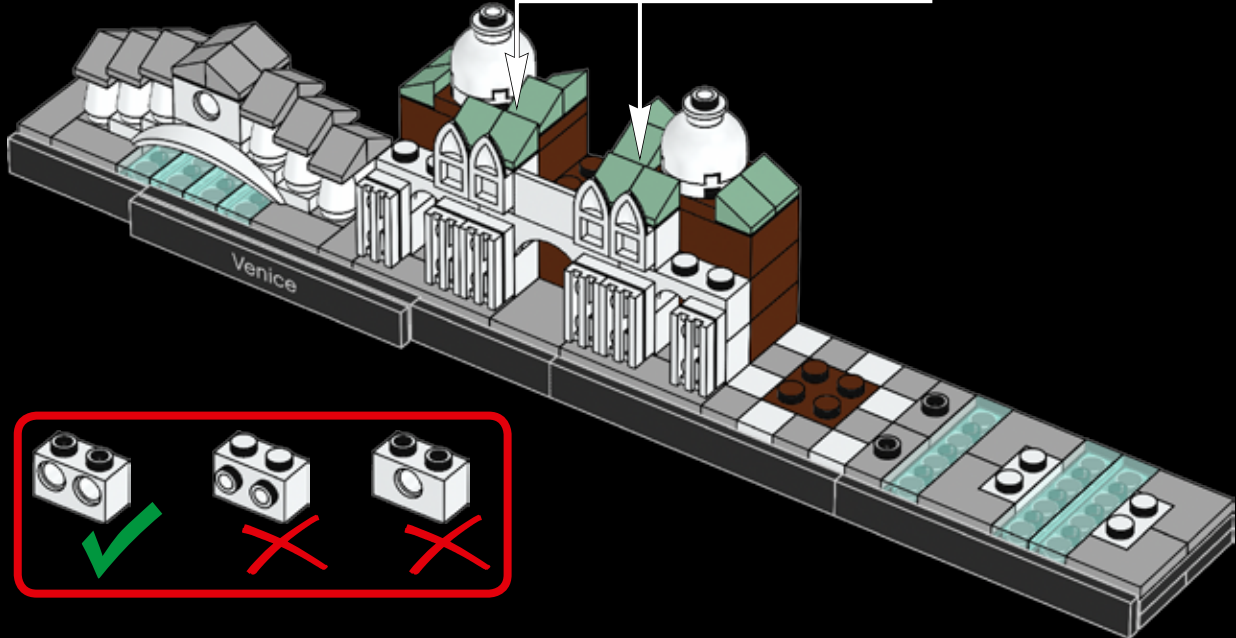
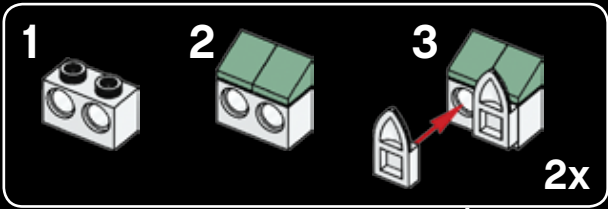



2x



2x

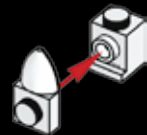

2x

47

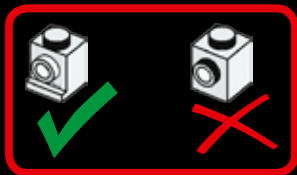
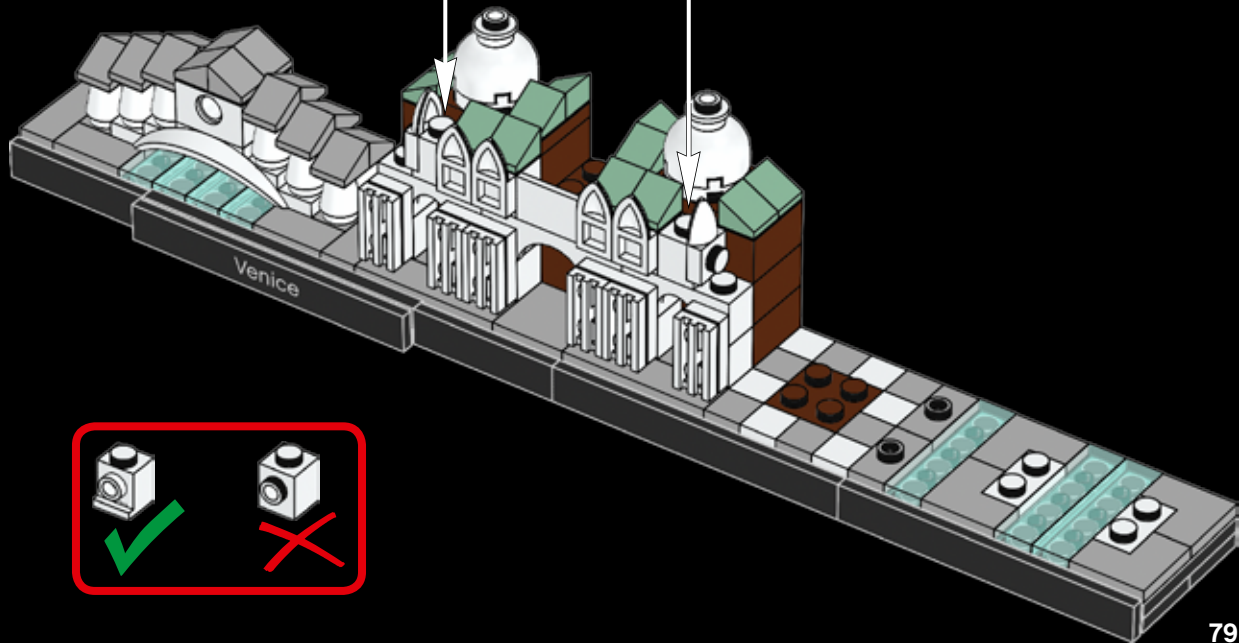



1x



1x

1

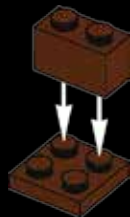

1x

2





1x

3



1x

4





1x



1x

5



2x



1x

6

1

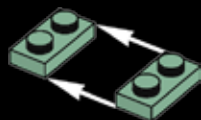

2

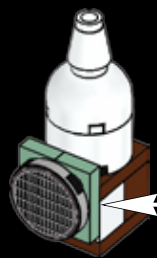
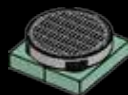

48

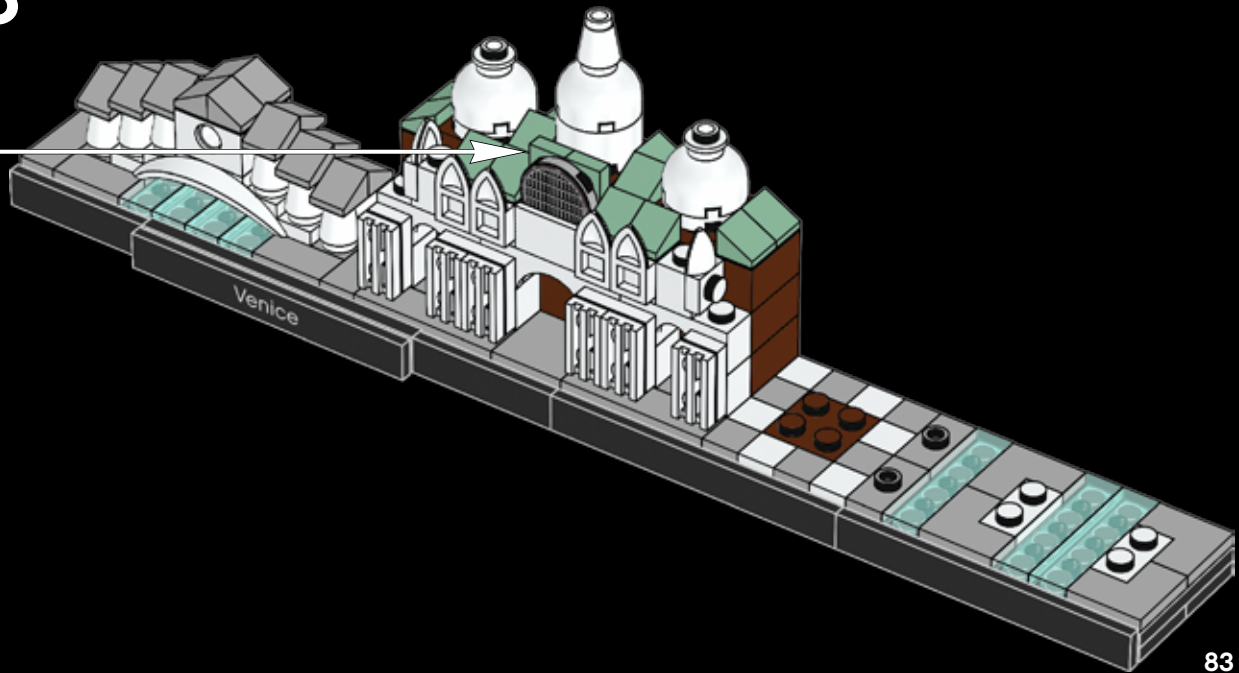



1

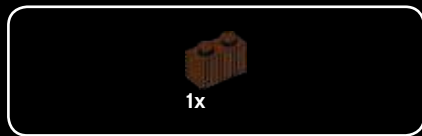
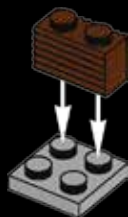

2



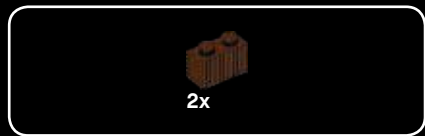

3

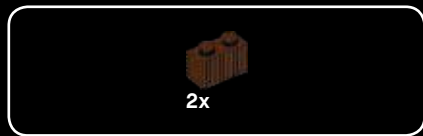

4





5



6



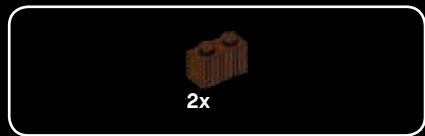

7

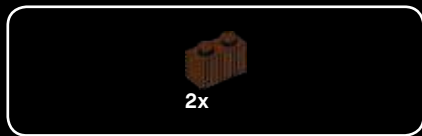

8





2x

9



2x

10





1x



1x

11



1x

12





1x



1x

13



49

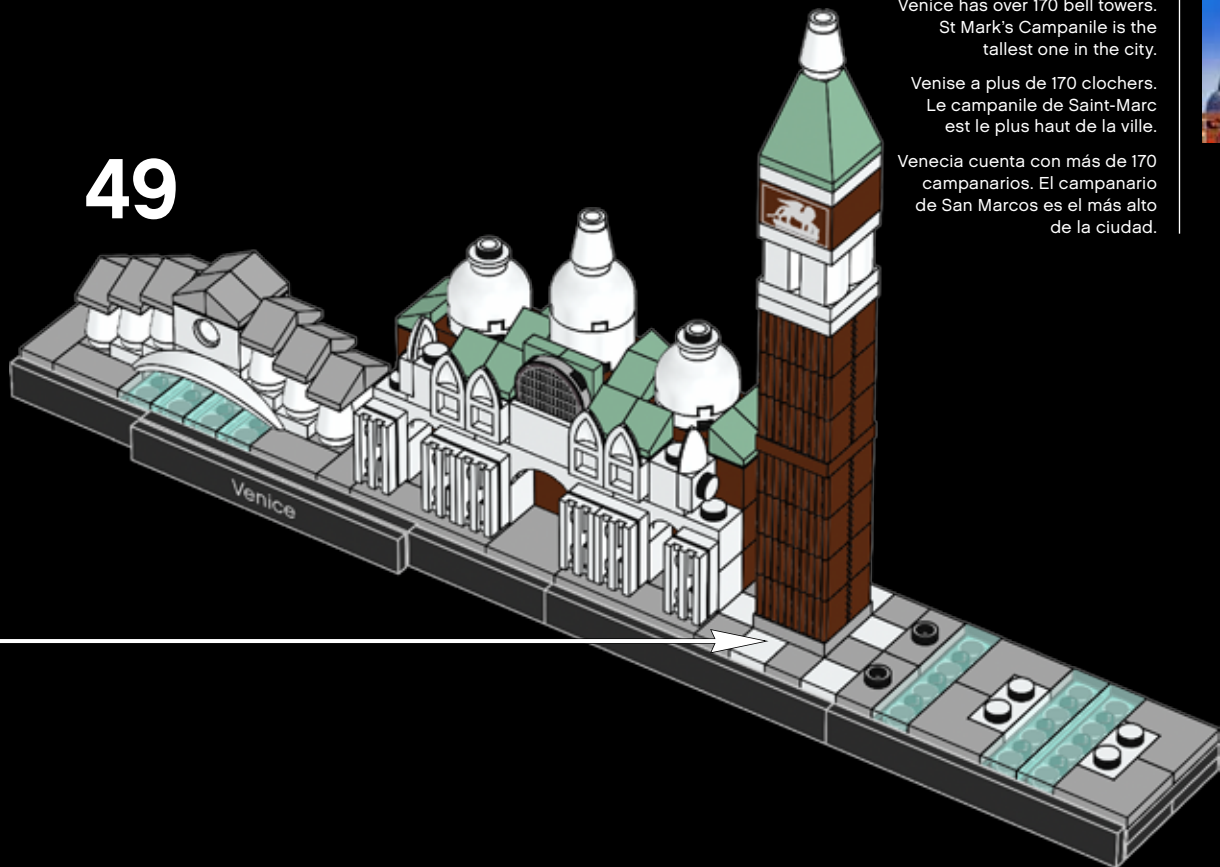

Venice has over 170 bell towers.
St Mark's Campanile is the tallest one in the city.

Venise a plus de 170 clochers.
Le campanile de Saint-Marc est le plus haut de la ville.

Venecia cuenta con más de 170 campanarios.
El campanario de San Marcos es el más alto de la ciudad.



© KKulikov



2x

50

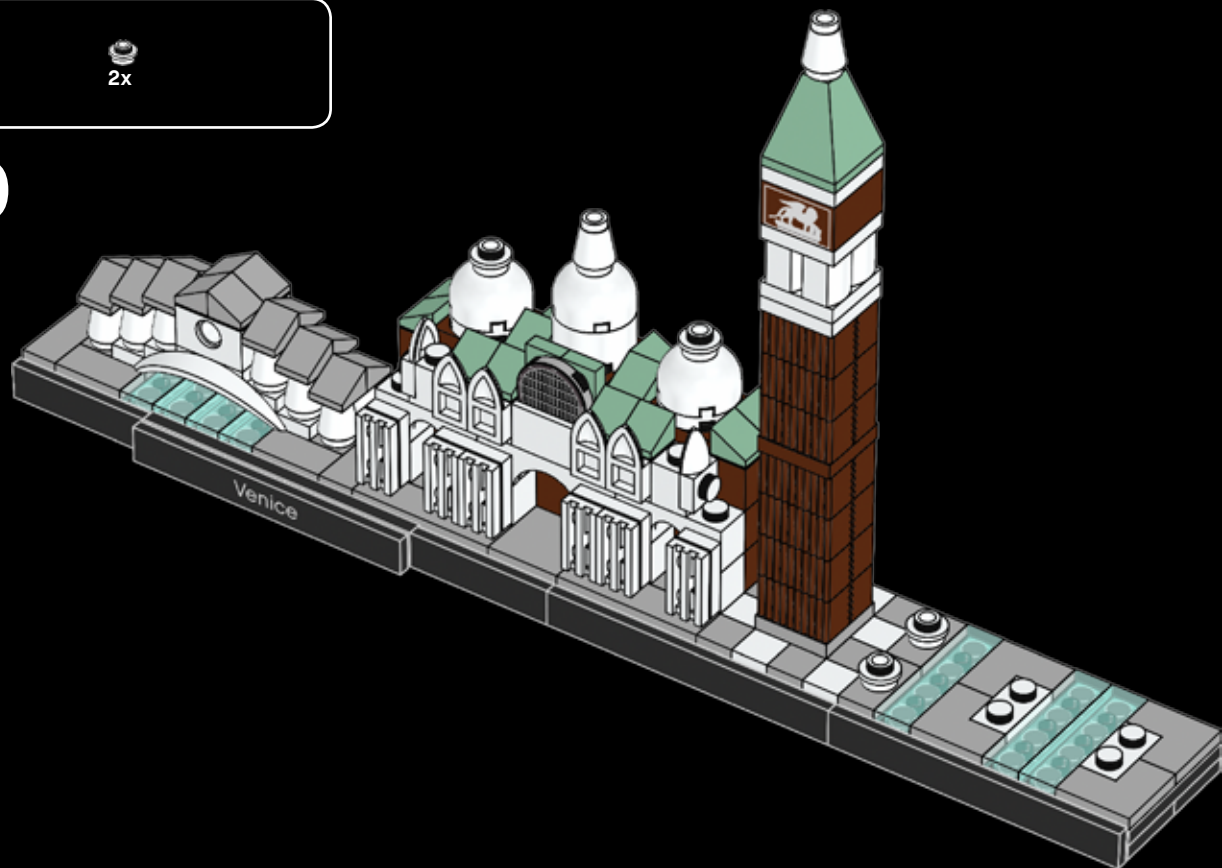



2x

51

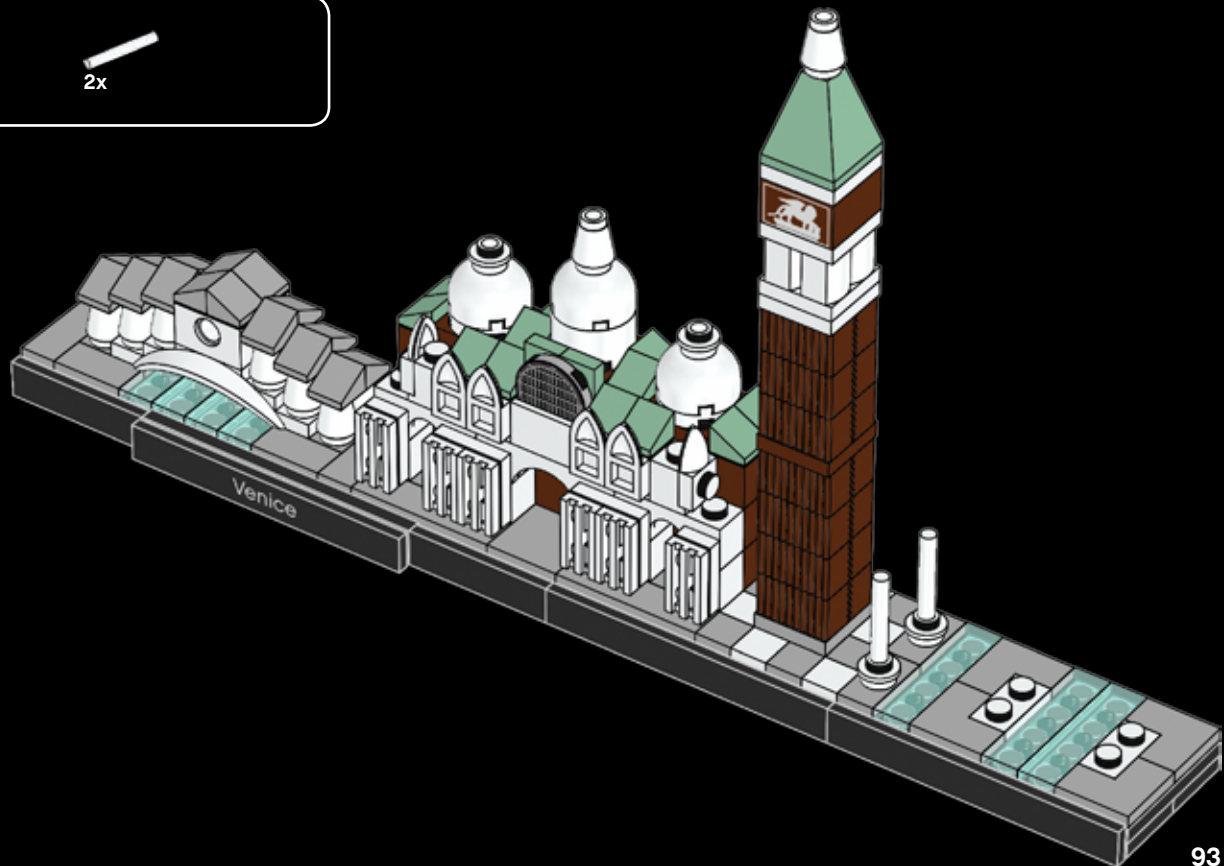



1x



1x

52

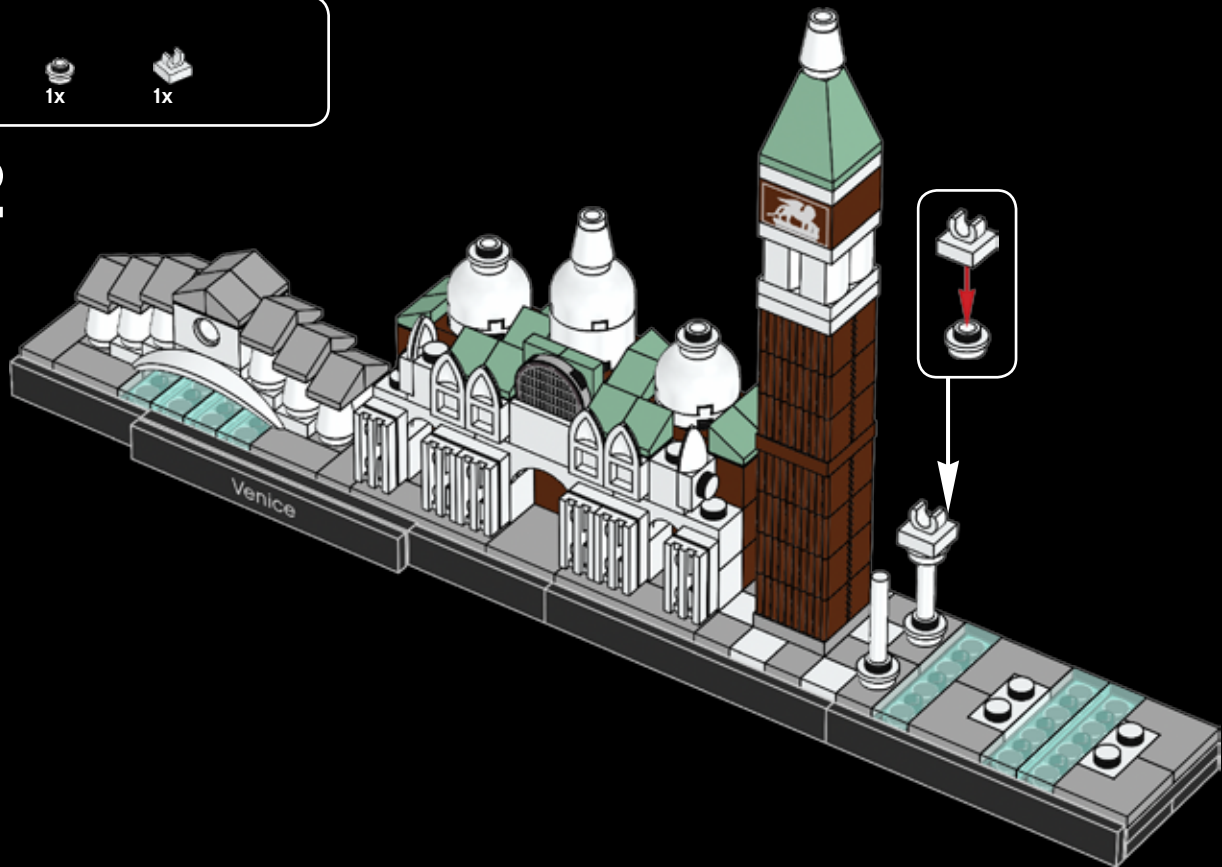



1x



1x

53

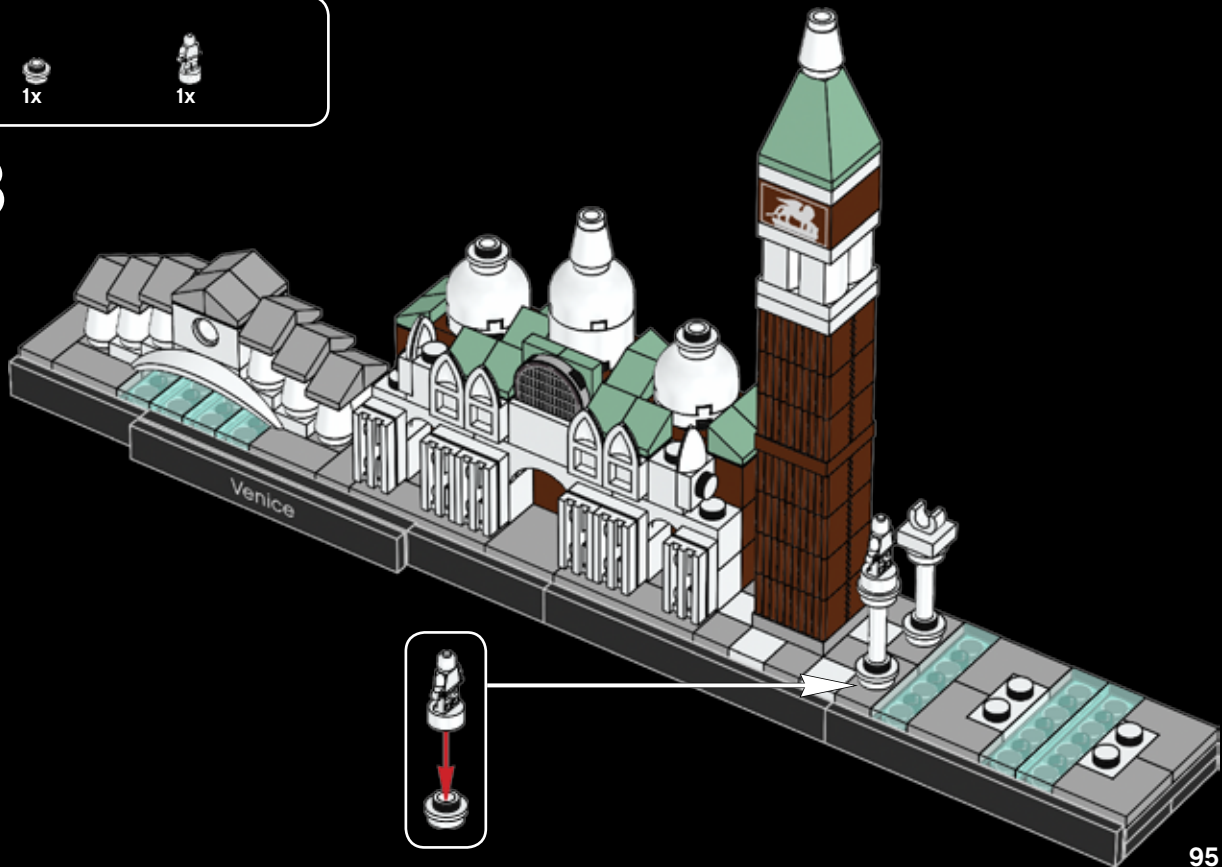



2x

54

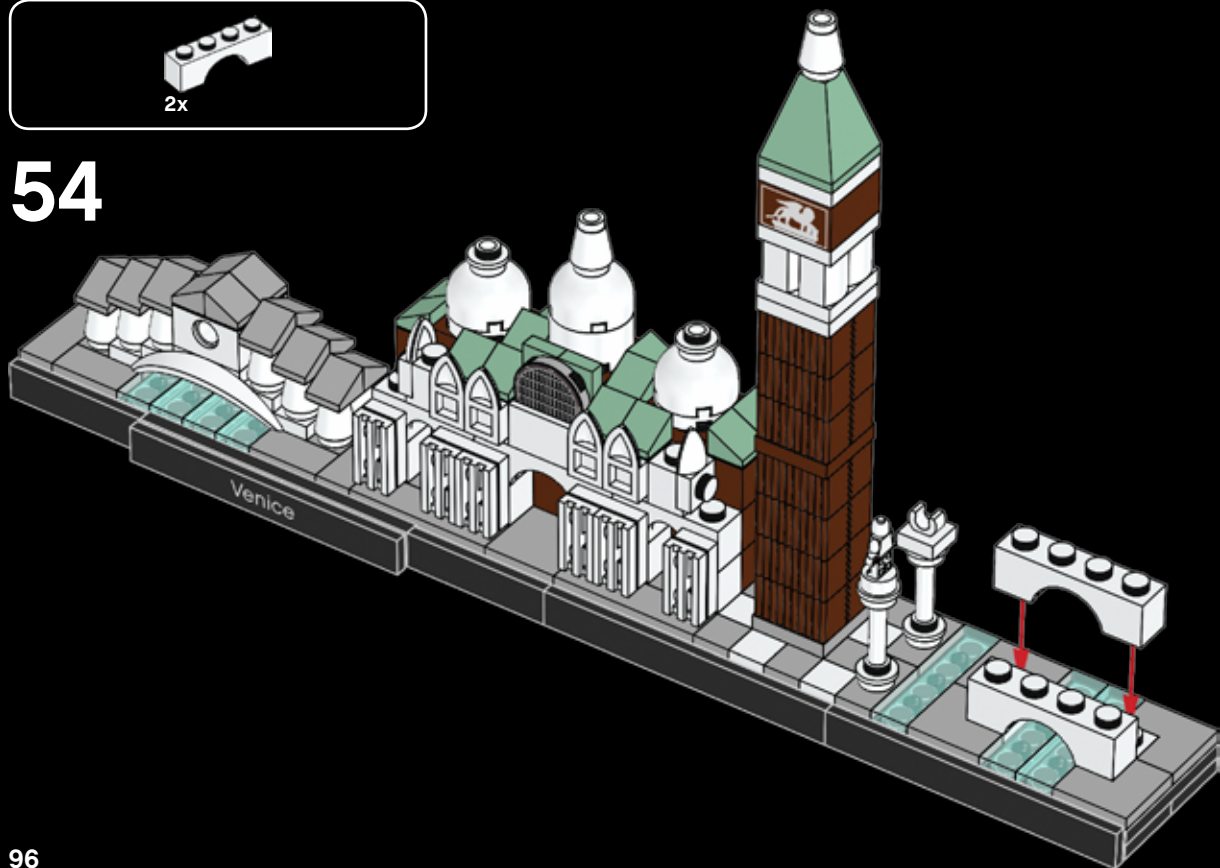



2x

55

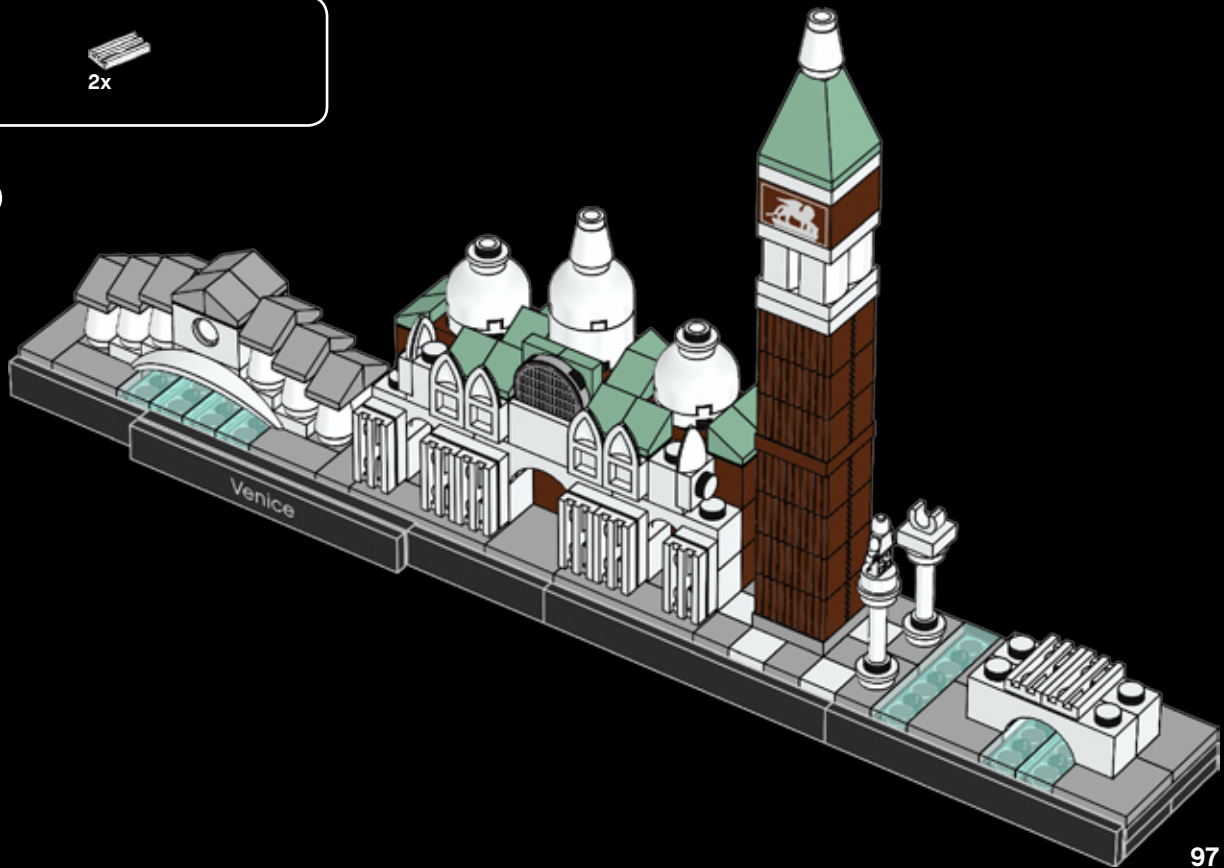



2x

56

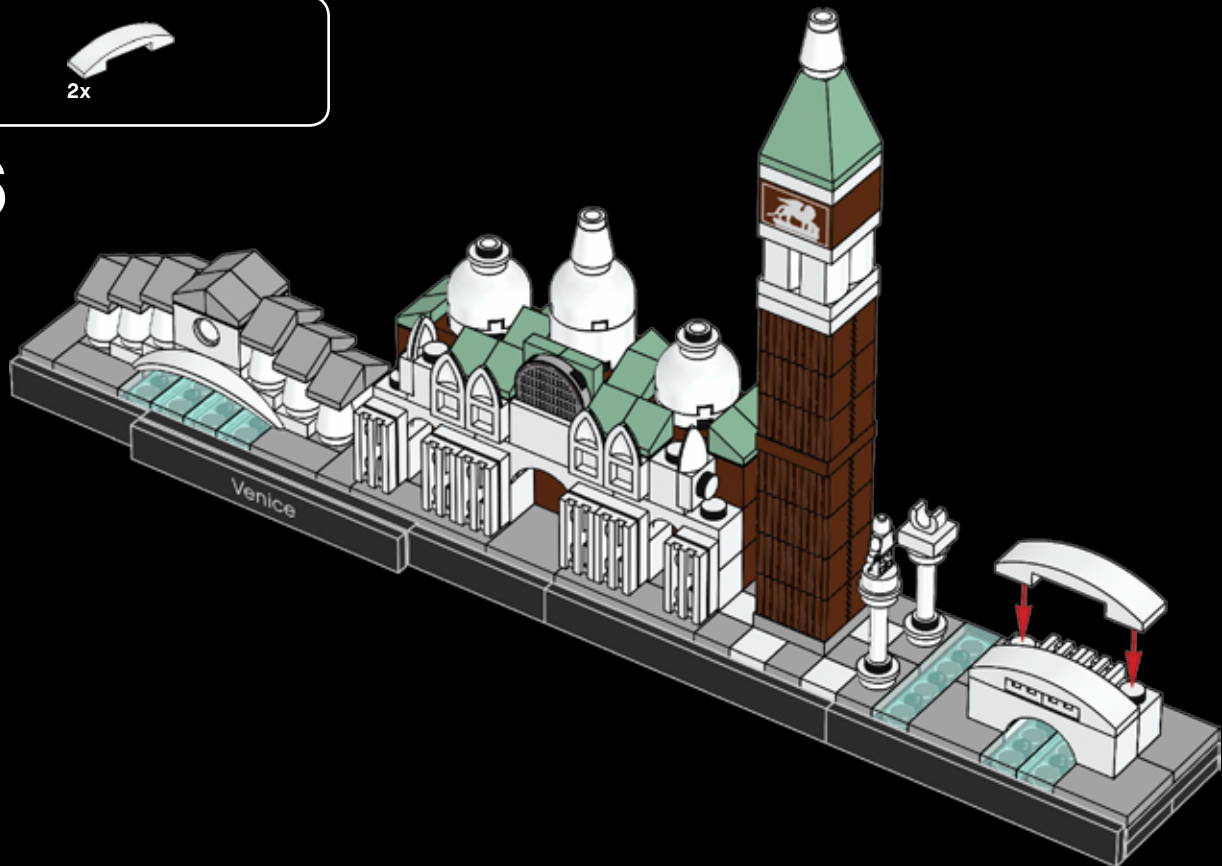



LEGO® Architecture—then and now

There has always been a natural connection between the LEGO® brick and the world of architecture. Fans who build with LEGO elements instinctively develop an interest in the form and function of the structures they create. At the same time, many architects have discovered that LEGO bricks are the perfect way of physically expressing their creative ideas.

This connection was confirmed in the early 1960s with the launch of the LEGO 'Scale Model' line. It matched the spirit of the age where modern architects were redefining how houses look and people were taking an active interest in the design of their new homes. These sets were designed to be different from the normal, brightly colored LEGO boxes; they also included a book on architecture as a source of inspiration.

Decades later, architect and LEGO fan Adam Reed Tucker revived the idea of expressing architecture using LEGO bricks and in partnership with the LEGO Group,

launched the LEGO Architecture line that we know today. His first models, and the original sets in the current LEGO Architecture series, were interpretations of famous skyscrapers from his hometown of Chicago. Since then LEGO Architecture has developed and evolved, first with well-known buildings from other cities in the United States, and now with iconic structures from Europe, the Middle East and Asia.

The introduction of our LEGO Architecture Studio set echoes the ambitions of the earlier LEGO 'Scale Model' line and widens the potential of the LEGO Architecture series. Now you can enjoy building and learning about specific landmark buildings, or create exciting architectural models from your own fantasy. An inspiring 270-page book, featuring a number of renowned architects from around the world, guides you through the principles of architecture and encourages you in your own creative building.

LEGO® Architecture – Hier et aujourd'hui

Il y a toujours eu une connexion naturelle entre la brique LEGO® et le monde de l'architecture. Les fans qui construisent avec des éléments LEGO développent instinctivement un intérêt pour la forme et la fonction des structures qu'ils créent. De nombreux architectes ont quant à eux découvert que les briques LEGO sont la façon idéale de matérialiser leurs idées de création.

Cette connexion a été confirmée au début des années 1960 avec le lancement de la gamme « Maquettes à l'échelle » LEGO. Cette gamme correspondait à l'esprit de l'époque, alors que les architectes modernes redéfinissaient les maisons, et que les gens s'intéressaient activement à la conception de leur résidence. Ces ensembles originaux étaient conçus pour être différents des boîtes LEGO habituelles aux couleurs vives, et incluaient aussi un livret d'architecture comme source d'inspiration.

Quelques décennies plus tard, l'architecte et fan de LEGO Adam Reed Tucker a fait revivre l'idée d'exprimer l'architecture en utilisant des briques LEGO. En

partenariat avec le Groupe LEGO, il lança la gamme LEGO Architecture que nous connaissons aujourd'hui. Ses premiers modèles, et les ensembles originaux de la gamme LEGO Architecture actuelle, étaient des interprétations de célèbres gratte-ciel de sa ville natale de Chicago. La gamme LEGO Architecture a depuis évolué et s'est élargie, tout d'abord avec des bâtiments célèbres d'autres villes des États-Unis, puis avec de célèbres monuments d'Europe, du Moyen-Orient et d'Asie.

L'introduction de notre ensemble LEGO Architecture Studio fait écho aux ambitions de la précédente gamme « Maquettes à l'échelle » LEGO et accroît le potentiel de la gamme LEGO Architecture. Vous pouvez maintenant découvrir et construire des monuments célèbres ou créer de passionnants modèles architecturaux nés de votre imagination. Un livret d'inspiration de 270 pages, présentant plusieurs architectes célèbres du monde entier, vous guide parmi les principes de l'architecture et vous encourage dans votre propre construction créatrice.

LEGO® Architecture: entonces y ahora

Siempre ha existido una conexión natural entre el brick LEGO® y el mundo de la arquitectura. Los fans que construyen con elementos LEGO desarrollan instintivamente un interés por la forma y las funciones de las estructuras que crean. Al mismo tiempo, muchos arquitectos han descubierto que los bricks LEGO son una forma perfecta de expresar físicamente sus ideas creativas.

Esta relación se confirmó a principios de la década de 1960, con el lanzamiento de la línea «Scale Model» de LEGO. Encajaba bien con el espíritu de la época: un tiempo en el que los arquitectos modernos redefinían el aspecto de las casas y la gente se interesaba cada vez más por el diseño de su nuevo hogar. Los sets se diseñaron para que se diferenciaban de los normales, que se comercializaban en cajas de brillantes colores, e incluían un libro sobre la arquitectura que proporcionaba inspiración a sus usuarios.

Décadas más tarde, el arquitecto y fan de LEGO Adam Reed Tucker reavivó la idea de expresar la arquitectura

usando bricks LEGO y, en colaboración con The LEGO Group, lanzó la línea LEGO Architecture que hoy conocemos. Sus primeros modelos, y los sets originales de la actual serie LEGO Architecture, eran interpretaciones de los rascacielos más famosos de su ciudad natal, Chicago. Desde entonces, LEGO Architecture se ha desarrollado y ha evolucionado, primero incorporando edificios célebres de otras ciudades de Estados Unidos y, ahora, estructuras emblemáticas de Europa, Oriente Próximo y Asia.

La introducción del set LEGO Architecture Studio recupera las ambiciones de la antigua línea «Scale Model» de LEGO y amplía el potencial de la serie LEGO Architecture. Hoy puedes disfrutar mientras construyes y aprendes sobre edificios célebres, o crear tus propios modelos arquitectónicos a partir de tu imaginación. Un instructivo libro de 270 páginas con materiales creados por arquitectos internacionales de gran reputación te guiará a través de los principios de la arquitectura y te animará a dar tus primeros pasos en el mundo de la construcción creativa.



21050
Studio

Celebrate the world of architecture and collect all the models
Célébrez le monde de l'architecture et collectionnez tous les modèles
Celebra el mundo de la arquitectura y colecciona todos los modelos

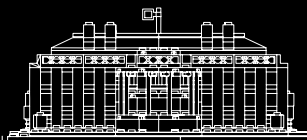

21006
The White House
La Maison-Blanche
La Casa Blanca

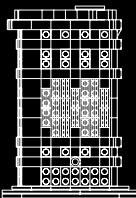

21023
Flatiron Building
Le Flatiron Building
Edificio Flatiron

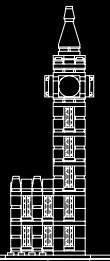

21013
Big Ben



21024
Louvre

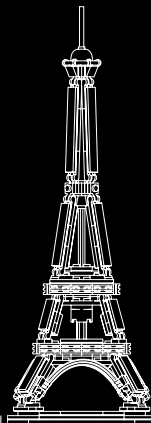

21019
The Eiffel Tower
La tour Eiffel
La torre Eiffel

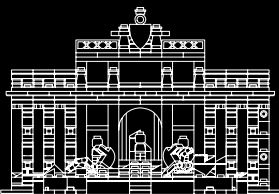

21020
Trevi Fountain
La fontaine de Trevi
Fontana de Trevi

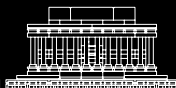

21022
Lincoln Memorial
Le monument de Lincoln
Monumento a Lincoln



21027
Berlin
Berlin



21028
New York City
New York
Nueva York

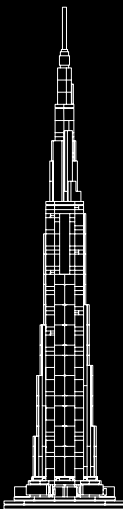

21031
Burj Khalifa

References

Pictures -

© Shutterstock

© Iakov Kalinin

© pio3

© KKulikov

© TTstudio

© Kite_rin

Text -

www.comune.venezia.it

www.basilicasanmarco.it

Références

Images -

© Shutterstock

© Iakov Kalinin

© pio3

© KKulikov

© TTstudio

© Kite_rin

Texte -

www.comune.venezia.it

www.basilicasanmarco.it

Referencias

Fotografías -

© Shutterstock

© Iakov Kalinin

© pio3

© KKulikov

© TTstudio

© Kite_rin

Texto -

www.comune.venezia.it

www.basilicasanmarco.it

1x
6073432

14x
4518400

6x
4547649

1x
6054551

2x
407001

2x
4558952

6x
307001

6x
4224792

2x
403201

3x
4216652

1x
614301

2x
6059185

2x
3200001

3x
6058177

8x
241201

2x
370001

4x
302301

1x
486501

2x
6093526

6x
302201

2x
4520970

3x
365901

2x
6023806

2x
4523556

4x
302326

2x
302226

2x
243126

4x
371026

5x
4653049

1x
6135202

4x
346026

2x
416226

6x
303426

7x
4586557

12x
4652205

2x
4655080

1x
6136563

14x
4223303

3x
4211149

4x
4216695

1x
6142085

2x
4211189

2x
4216668

5x
4211201

16x
4521921

6x
4211415

1x
6052204

2x
6066097

4x
4211414



4x
4211397

1x
4211413

4x
6065824

2x
4599498

4x
4211356

2x
4211462

Customer Service
Kundenservice
Service Consommateurs
Servicio Al Consumidor
LEGO.com/service or dial

00800 5346 5555 : 
1-800-422-5346 : 



LEGO and the LEGO logo are
trademarks of the
LEGO Group.
©2016 The LEGO Group. 6160898



LEGO.com/architecture